

Bridges

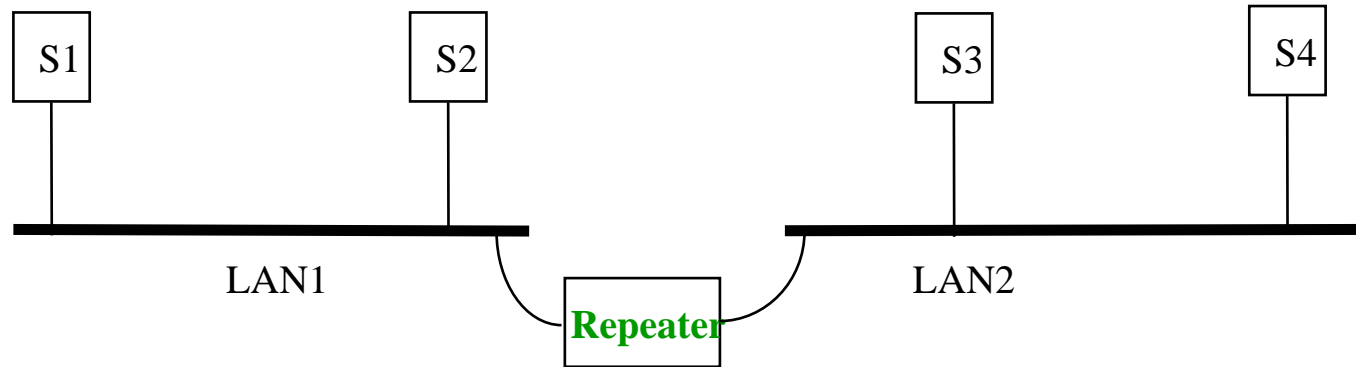

A repeater operates at the physical layer and forwards everything between the two LANs.

LAN1 and LAN2 are in the same collision domain.

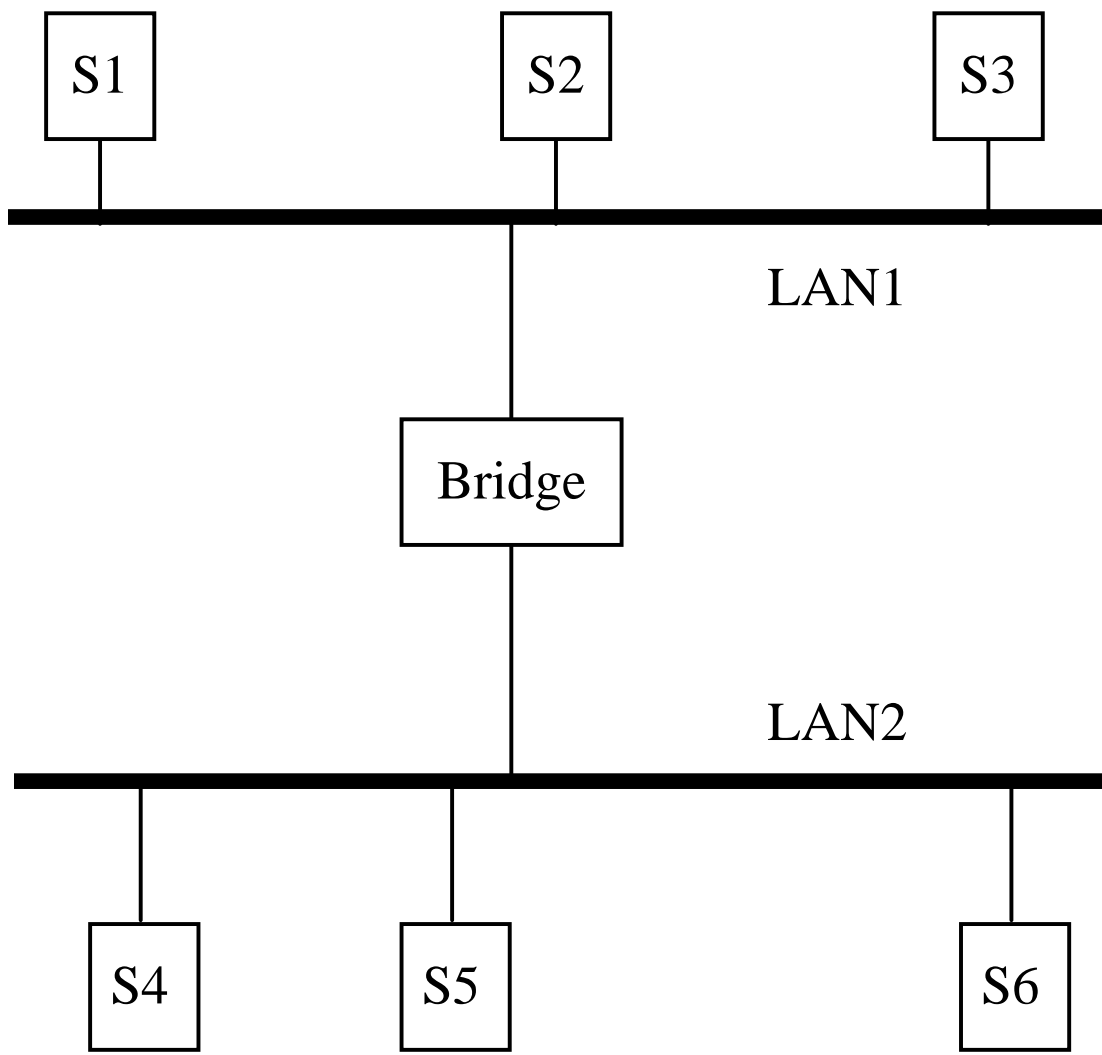

Bridges

- Operate at the data link layer.
- Bridges use backward learning in recording source address on transmissions.
- Unlike repeaters, bridges will not forward a frame onto another LAN segment if it knows about the location of the destination node.
- *Bridge management gets more complicated when loops are possible in the frame route.*

Bridge

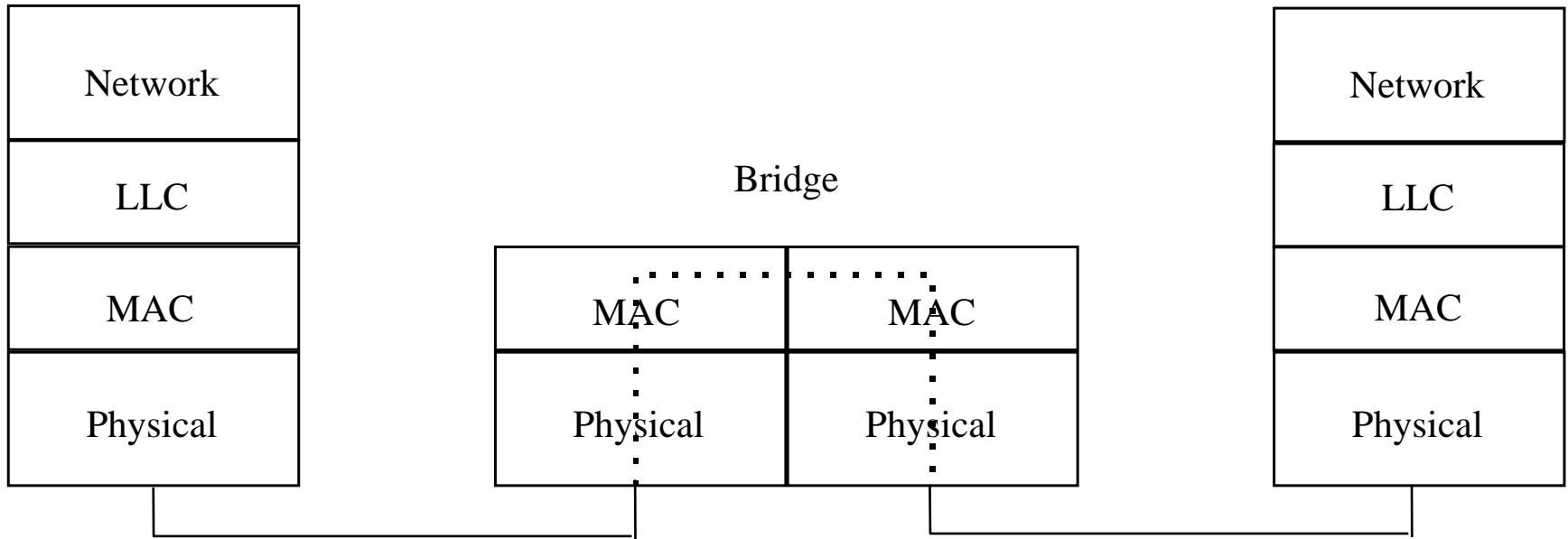

A bridge is a store and forward device that separates collision domains.

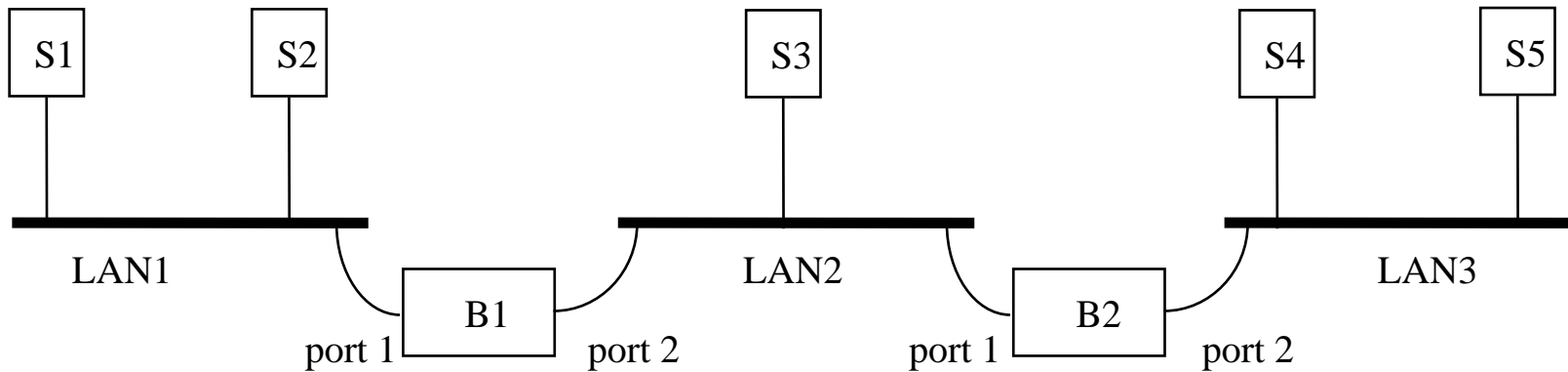

Address	Port

Address	Port

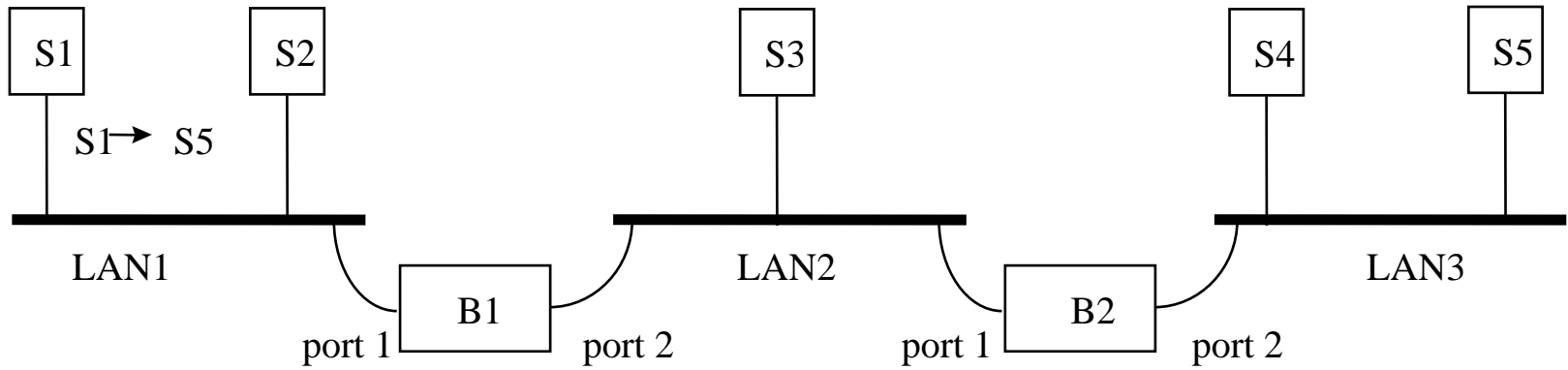

Address	Port
S1	1

Address	Port
S1	1

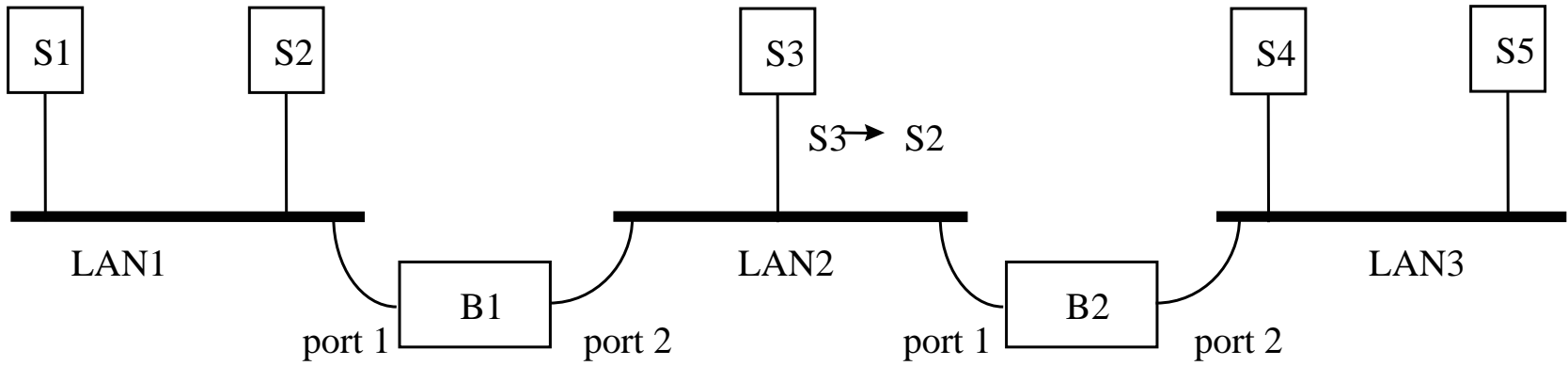

Address	Port
S1	1
S3	2

Address	Port
S1	1
S3	1

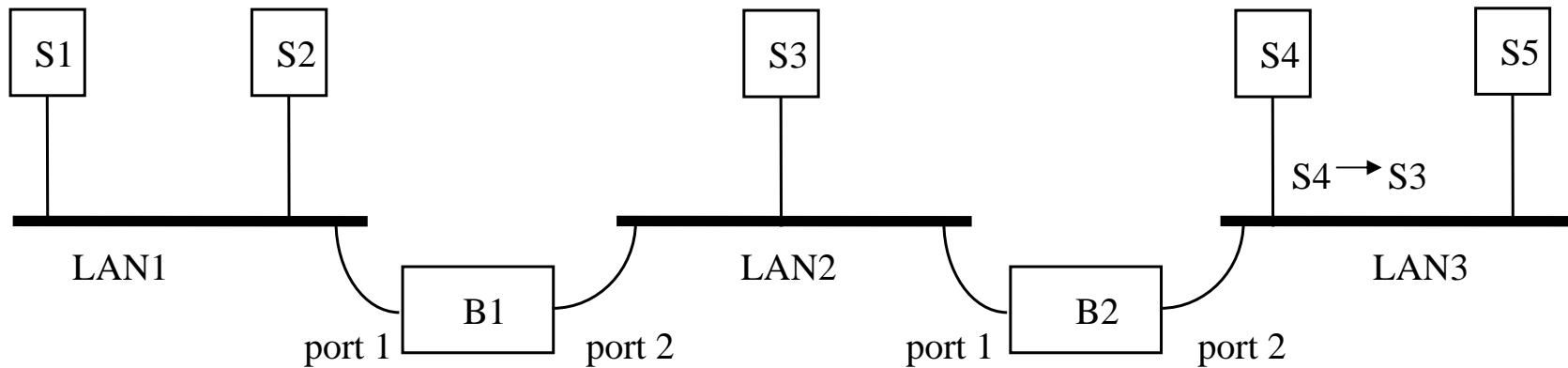

Bridge 1 does not forward the frame to LAN1

Address	Port
S1	1
S3	2
S4	2

Address	Port
S1	1
S3	1
S4	2

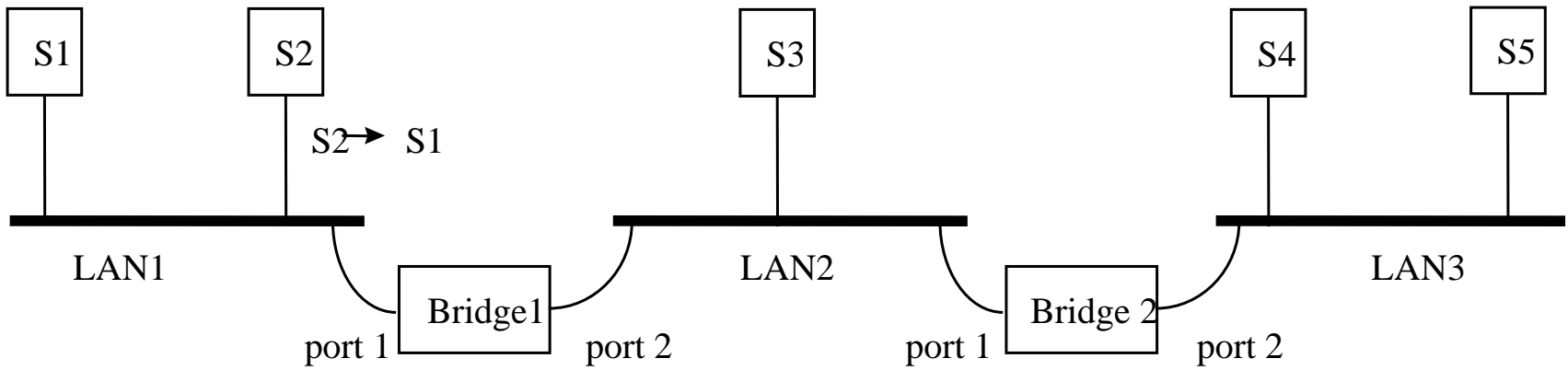

Bridge 1 does not forward the frame to LAN2

Address	Port
S1	1
S3	2
S4	2
S2	1

Address	Port
S1	1
S3	1
S4	2

MAN with Bridge Loops

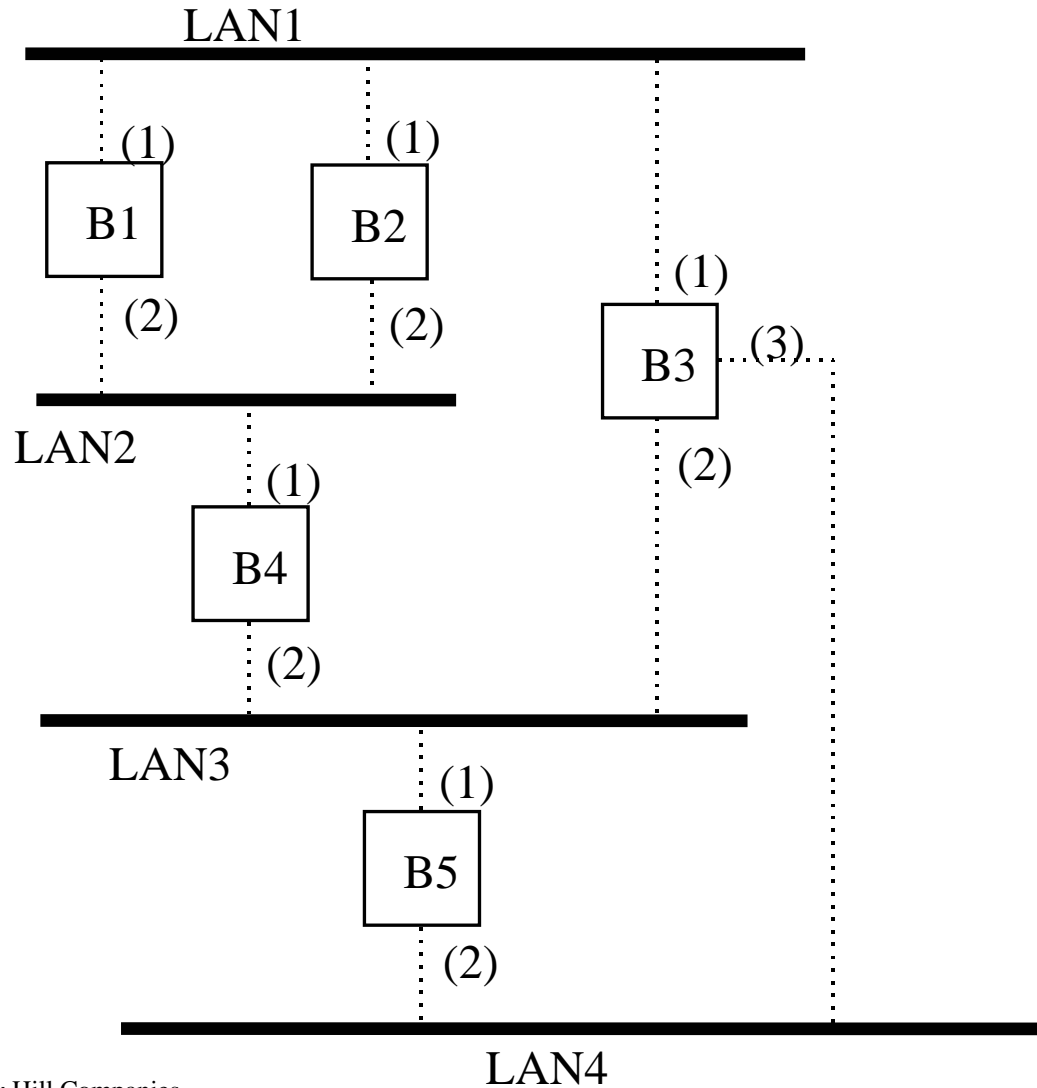

Copyright ©2000 The McGraw Hill Companies

Leon-Garcia & Widjaja: *Communication Networks*

Figure 6.86

Networks: Bridges

11



MAN with Bridge Loops

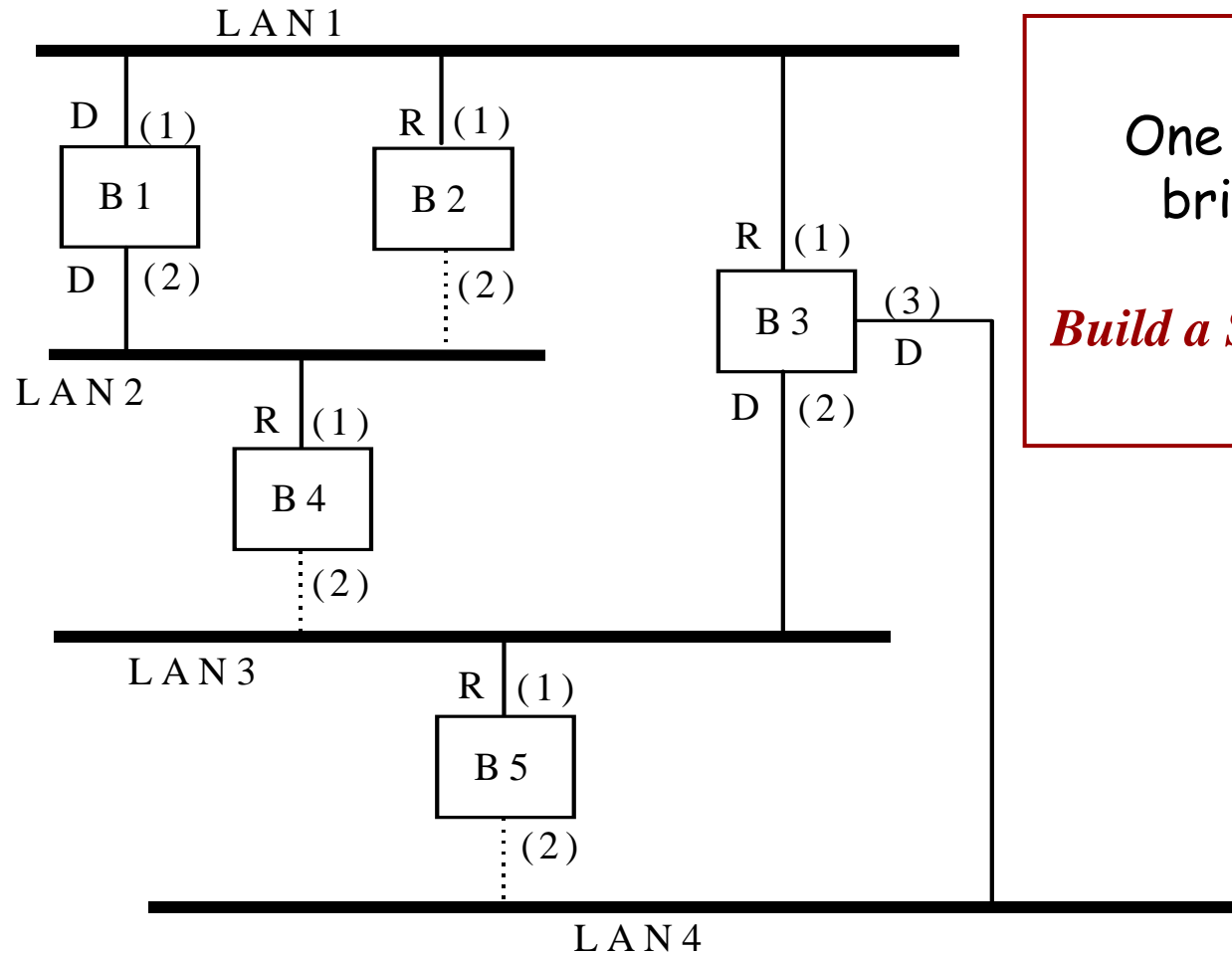

One solution to bridge loops

Build a Spanning Tree!