

# Physical Layer (part 3) Transmission Media



**Advanced Computer Networks**

# Transmission Media Choices

- **Twisted Pair**
- **Coaxial Cable**
- **Optical Fiber**
- **Wireless Communications**

# Transmission Media

**Transmission medium**:: the physical path between transmitter and receiver.

- Repeaters or amplifiers may be used to extend the length of the medium.
- Communication of electromagnetic waves is *guided* or *unguided*.

*Guided media*:: waves are guided along a physical path (e.g., twisted pair, coaxial cable and optical fiber).

*Unguided media*:: means for transmitting but not guiding electromagnetic waves (e.g., the atmosphere and outer space).

# Telecommunications Spectrum

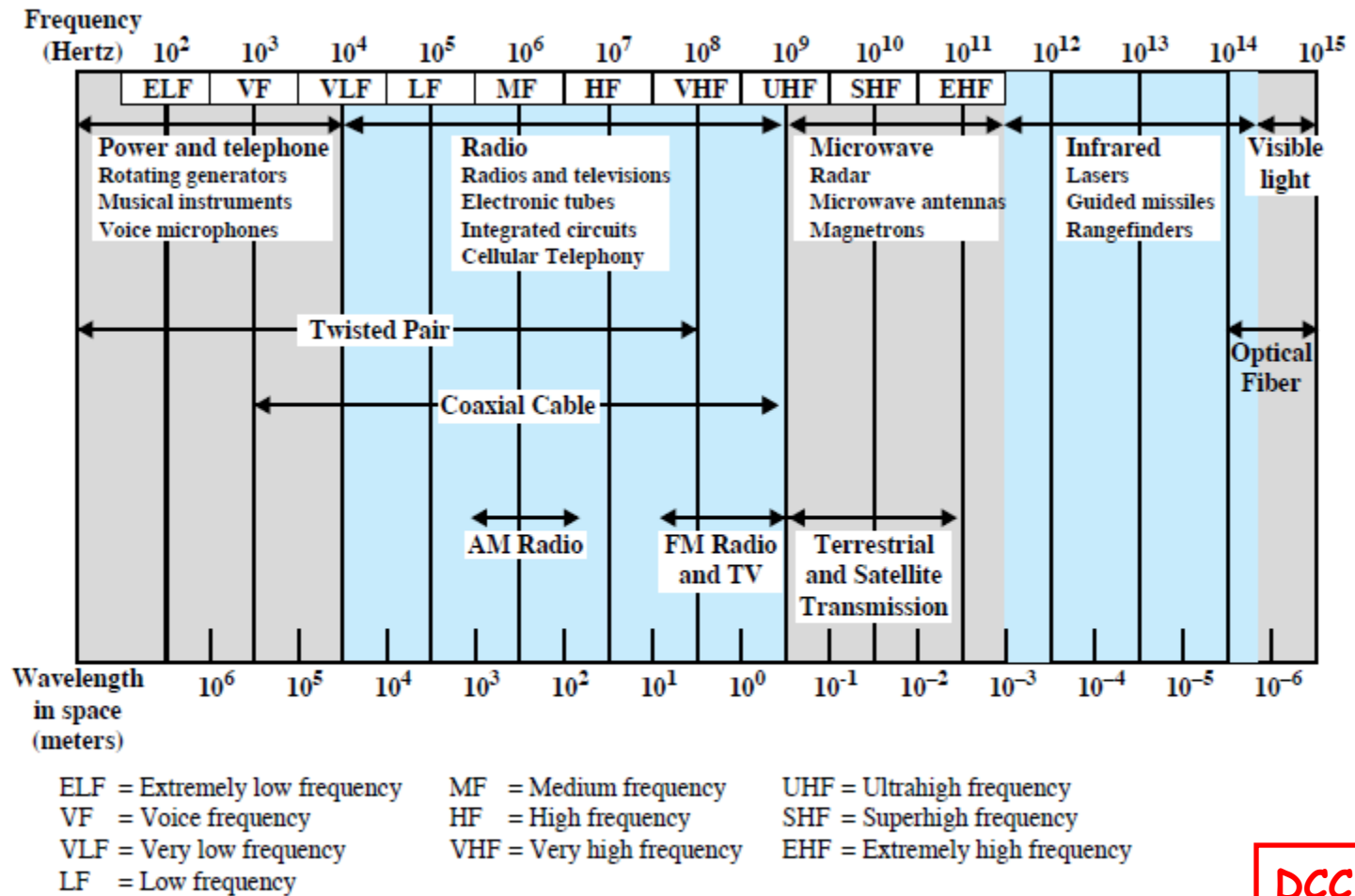

Figure 4.1 Electromagnetic Spectrum for Telecommunications

DCC 8<sup>th</sup> Ed.  
Stallings

# Guided Media Characteristics

Table 4.1 Point-to-Point Transmission Characteristics of Guided Media [GLOV98]

	Frequency Range	Typical Attenuation	Typical Delay	Repeater Spacing
Twisted pair (with loading)	0 to 3.5 kHz	0.2 dB/km @ 1 kHz	50 $\mu$ s/km	2 km
Twisted pairs (multipair cables)	0 to 1 MHz	0.7 dB/km @ 1 kHz	5 $\mu$ s/km	2 km
Coaxial cable	0 to 500 MHz	7 dB/km @ 10 MHz	4 $\mu$ s/km	1 to 9 km
Optical fiber	186 to 370 THz	0.2 to 0.5 dB/km	5 $\mu$ s/km	40 km

THz = TeraHertz =  $10^{12}$  Hz

DCC 8<sup>th</sup> Ed.  
Stallings

# Twisted Pair

- Two insulated wires arranged in a spiral pattern.
- Copper or steel coated with copper.
- The signal is transmitted through one wire and a ground reference is transmitted in the other wire.
- Typically twisted pair is installed in building telephone wiring.
- Local loop connection to central telephone exchange is twisted pair.

# Twisted Pair

- Limited in distance, bandwidth and data rate due to problems with attenuation, interference and noise.
  - Issue: *cross-talk* due to interference from other signals.
  - “shielding” wire (shielded twisted pair (STP)) with metallic braid or sheathing reduces interference.
  - “twisting” reduces low-frequency interference and crosstalk.

# Twisted Pair

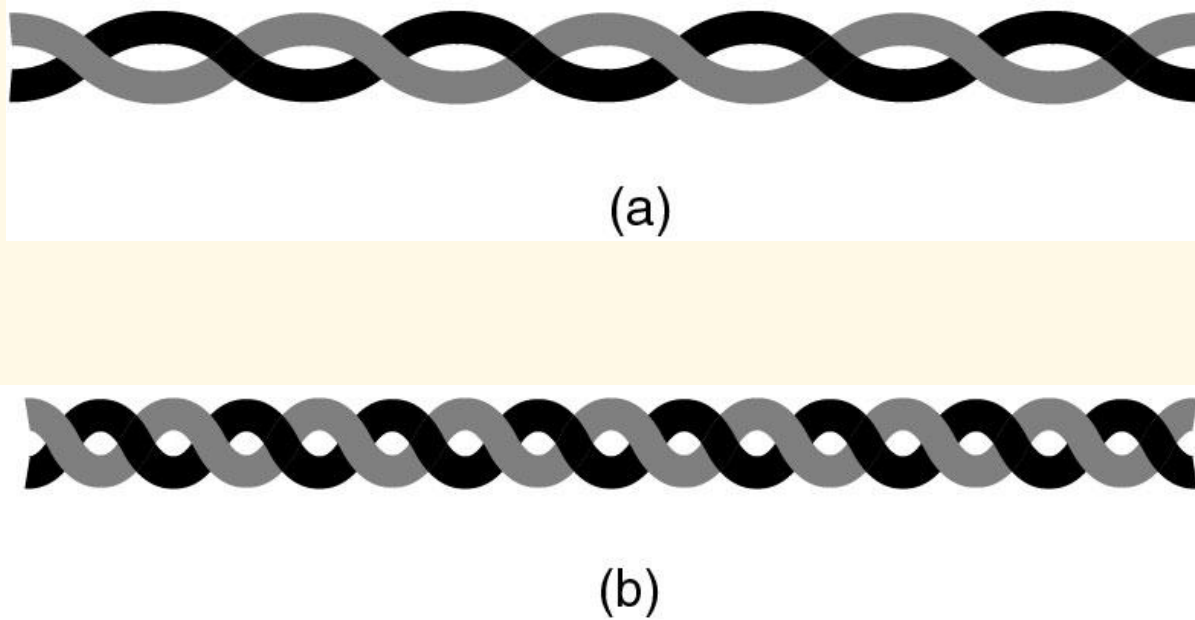

Fig 2-3. (a) Category 3 UTP.  
(b) Category 5 UTP.



# 10-BASE -T

10 Mbps baseband transmission over **twisted pair**.  
Two Cat 3 cables, Manchester encoding,  
Maximum distance - 100 meters

## Ethernet Hub

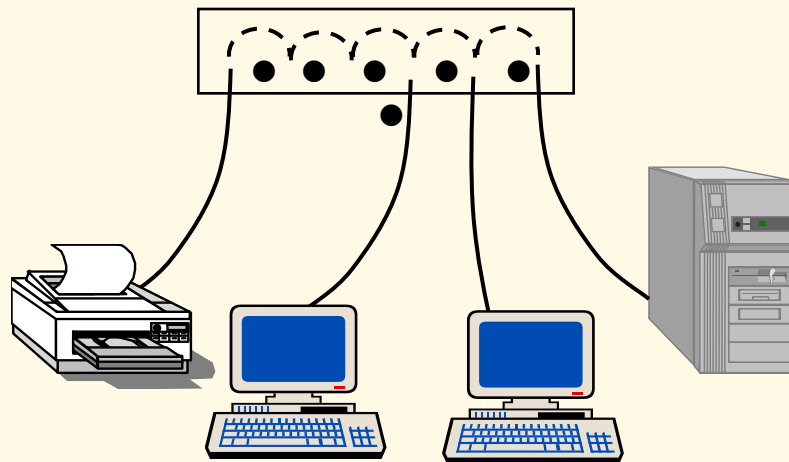

Leon-Garcia & Widjaja:  
*Communication Networks*

# Twisted Pair

Table 4.3 Twisted Pair Categories and Classes

	Category 3 Class C	Category 5 Class D	Category 5E	Category 6 Class E	Category 7 Class F
Bandwidth	16 MHz	100 MHz	100 MHz	200 MHz	600 MHz
Cable Type	UTP	UTP/FTP	UTP/FTP	UTP/FTP	SSTP
Link Cost (Cat 5 =1)	0.7	1	1.2	1.5	2.2

UTP = Unshielded twisted pair

FTP = Foil twisted pair

SSTP = Shielded screen twisted pair

DCC 8<sup>th</sup> Ed.  
Stallings

# EIA/TIA 568 and ISO/IEC 11801 Wiring Grades

Grade 1 - Unshielded Untwisted wiring.

Commonly called inside wire by the Telco community.

Grade 2 - Unshielded twisted pair (UTP) derived from IBM Type 3 spec.

**Category 3** - Unshielded twisted pair with 100 ohm impedance and electrical characteristics supporting transmission at frequencies up to **16 MHz**. May be used with 10Base-T, 100Base-T4, and 100Base-T2 Ethernet. **(Obsolete)**

**Category 4** - Unshielded twisted pair with 100 ohm impedance and electrical characteristics supporting transmission at frequencies up to **20 MHz**.

May be used with 10Base-T, 100Base-T4, and 100Base-T2 Ethernet.  
**(Obsolete)**

**Category 5** - Unshielded twisted pair with 100 ohm impedance and electrical characteristics supporting transmission at frequencies up to **100 MHz**.

May be used with 10Base-T, 100Base-T4, 100Base-T2, and 100Base-TX Ethernet.

May support 1000Base-T, but cable should be tested. **(Superseded by Cat5e)**

# EIA/TIA 568 and ISO/IEC 11801

## Wiring Grades

**\*Category 5e** - "Enhanced Cat 5" exceeds Cat 5 performance. Very similar to Cat 5, it has improved specifications for NEXT (Near End Cross Talk), PSÉLFEXT (Power Sum Equal Level Far End Cross Talk), and Attenuation. May be used for 10Base-T, 100Base-T4, 100Base-T2, 100BaseTX and 1000Base-T Ethernet. **(Minimum acceptable wiring grade)**

**Category 6** - In June 2002 TIA approved specification for Cat 6 doubling Cat 5 bandwidth to **250 MHz**. Cat 6 is backward compatible with lower Category grades and supports the same Ethernet standards as Cat 5e. A Cat 6 whitepaper is available from TIA. Currently there are no Ethernet standards that take advantage of Cat 6. ANSI/TIA854 is working on 1000Base-TX. When complete this standard will use two pair in each direction as opposed to all four for 1000Base-T over Cat 5e. This is expected to reduce the cost of Gigabit Ethernet implementations. 1000Base-TX will only operate over Cat6.

**Category 7** - Proposed standard to support transmission at frequencies up to **600 MHz** over 100 ohm twisted pair.

# EIA/TIA 568 and ISO/IEC 11801 Wiring Grades

## NOTES:

- 1) EIA 568 limits UTP copper cabling to maximum distance of 100 meters (328 feet). 90 meters of cable plus 10 meters of patch cord split between both ends.
- 2) The FCC recently changed the requirement for telephone inside wiring to minimum of Cat 3 due to crosstalk problems with nontwisted quad-four. Cat 3 is no longer recognized by TIA. **The minimum wiring grade for structured wiring is Cat 5e.**
- 3) For installation to meet specific Category requirements all components must meet or exceed the designated Category. Using a Cat 3 receptacle (or patch cord) on Cat 6 reduces performance to Cat 3.

# Dial-up Modem

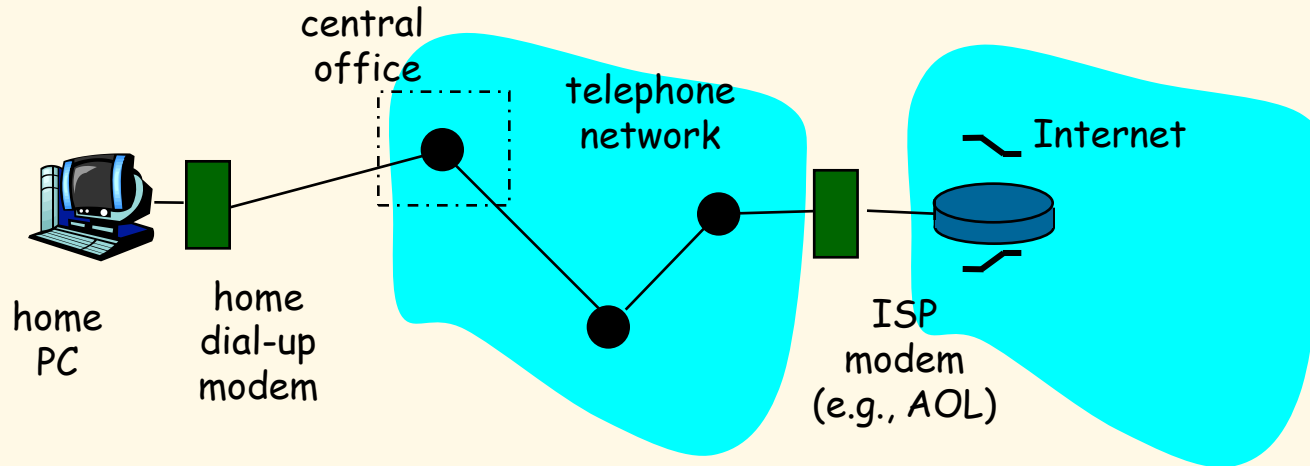

- Uses existing telephony infrastructure
  - Home is connected to **central office**.
- up to 56Kbps direct access to router (often less).
- Can't surf and phone at same time: not **"always on"**.

K & R

# Digital Subscriber Line

*Telephone companies originally transmitted within the 0 to 4K HZ range to reduce crosstalk. Loading coils were added within the subscriber loop to provide a flatter transfer function to further improve voice transmission within the 3K HZ band while increasing attenuation at the higher frequencies.*

## **ADSL** (Asymmetric Digital Subscriber Line)

- Uses existing twisted pair lines to provide higher bit rates that are possible with *unloaded twisted pairs* (i.e., there are no loading coils on the subscriber loop.)

# ADSL

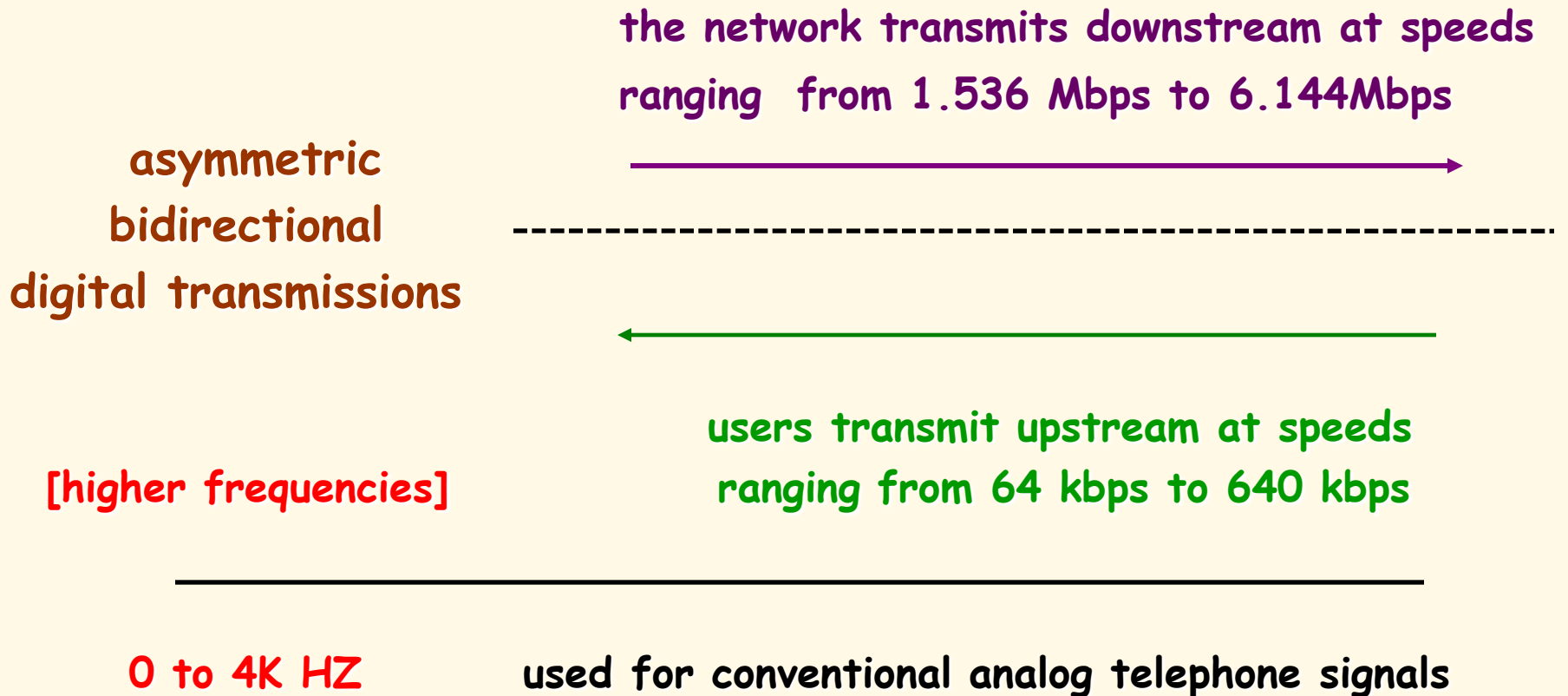



# Digital Subscriber Lines

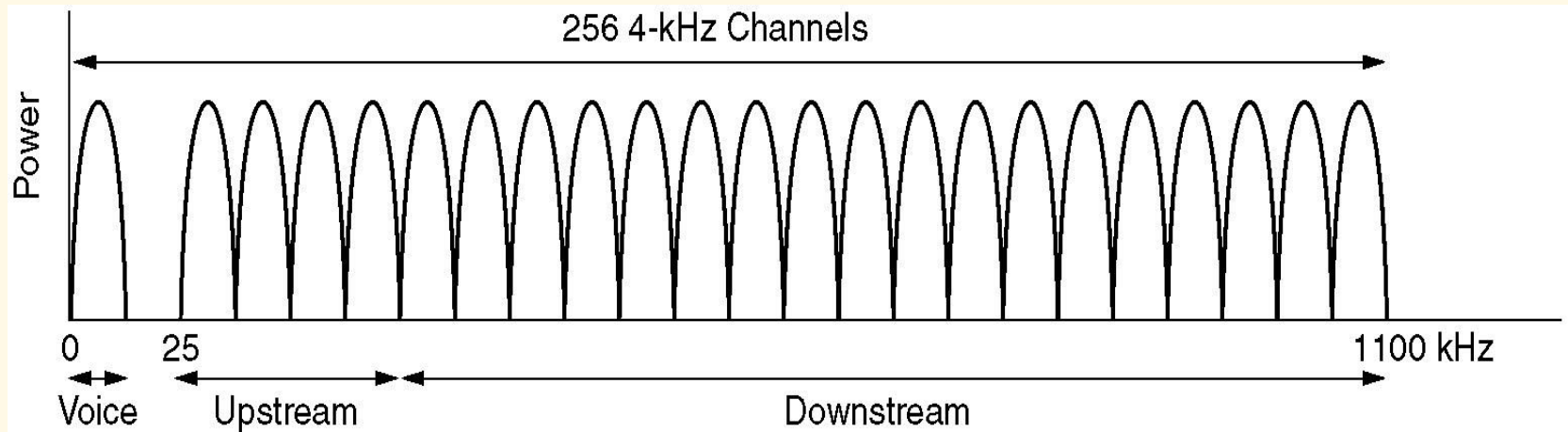

Figure 2-28. Operation of **ADSL** using discrete multitone modulation.

# ADSL

- ITU-T G992.1 ADSL standard uses Discrete Multitone (DMT) that divides the bandwidth into a large number of small subchannels.
- A **splitter** is required to separate voice signals from the data signal.
- The binary information is distributed among the subchannels. Each subchannel uses QAM.
- DMT adapts to line conditions by avoiding subchannels with poor SNR.

# Digital Subscriber Lines

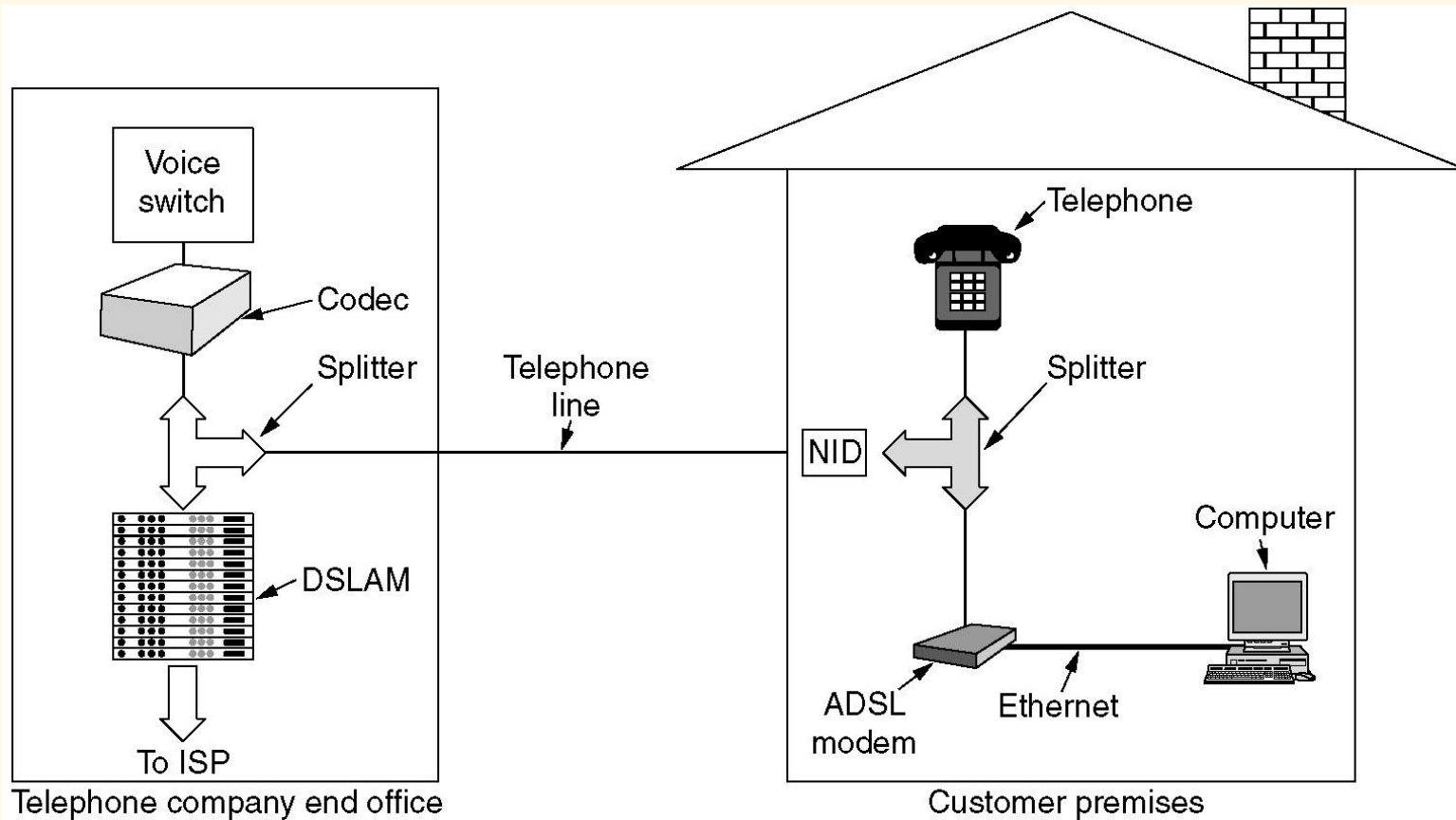
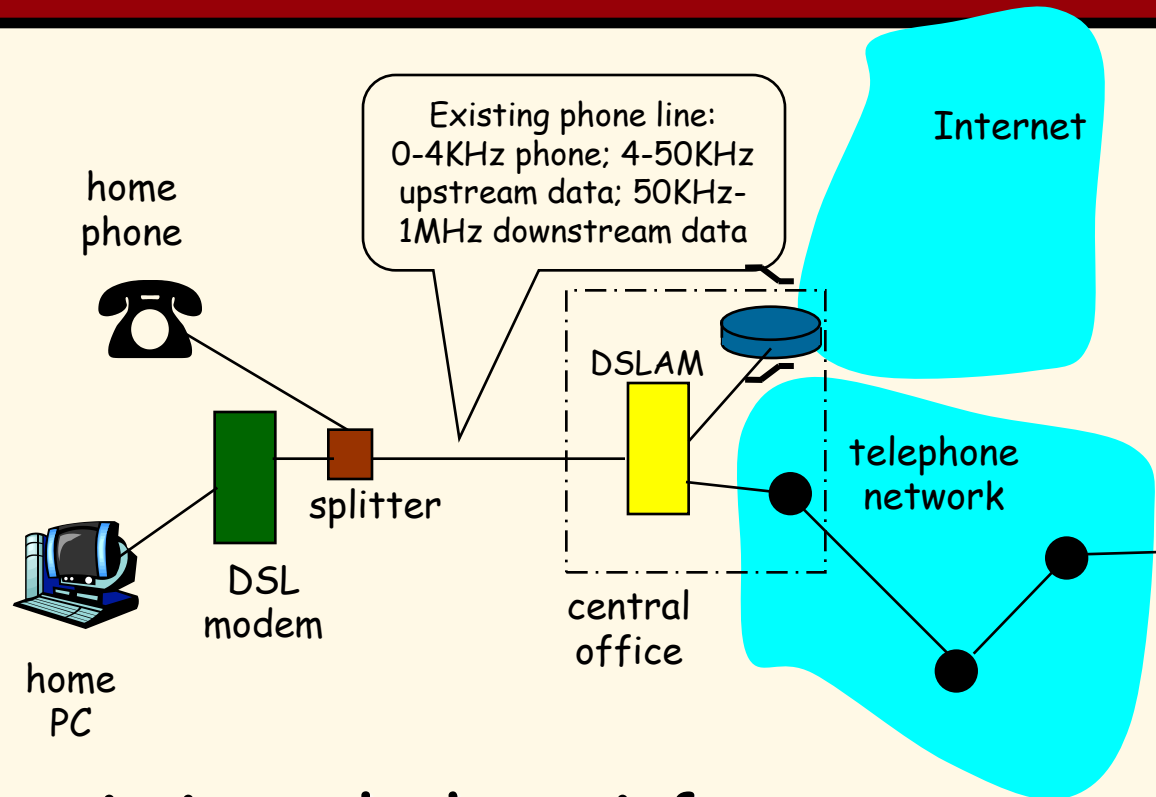

Figure 2-29. A typical ADSL equipment configuration.

Tanenbaum

# Digital Subscriber Line (DSL)



- Also uses existing telephone infrastructure.
- up to 1 Mbps upstream (today typically < 256 kbps)
- up to 8 Mbps downstream (today typically < 1 Mbps)
- dedicated physical line to telephone central office.

K & R

# Coaxial Cable

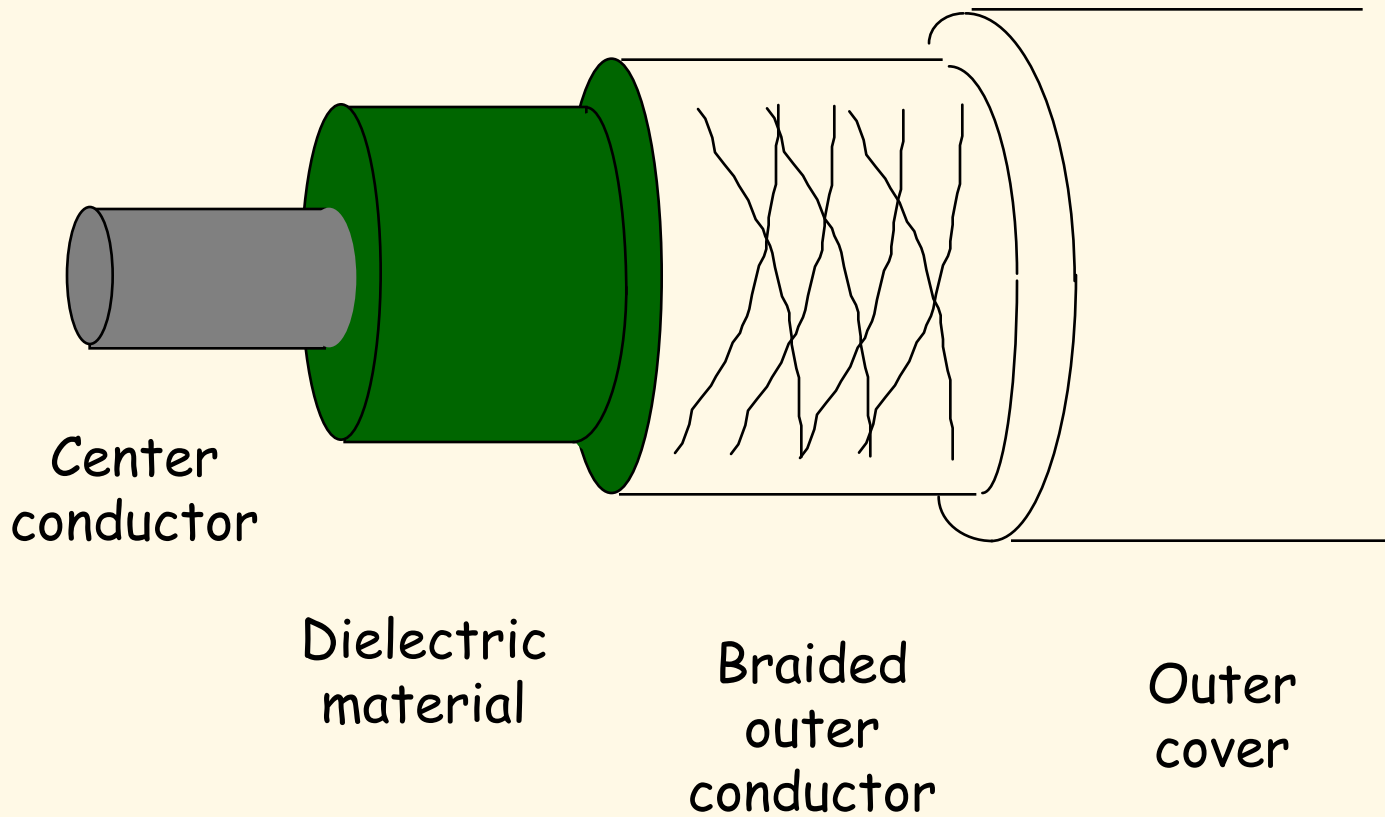

Leon-Garcia & Widjaja:  
*Communication Networks*

# Coaxial Cable

- Discussion divided into two basic categories for coax used in LANs:
  - 50-ohm cable [baseband]
  - 75-ohm cable [broadband or single channel baseband]
- In general, coaxial cable has better noise immunity for higher frequencies than twisted pair.
- Coaxial cable provides much higher bandwidth than twisted pair.
- However, the cable is 'bulky'.

# Baseband Coax

- 50-ohm cable is used exclusively for digital transmissions.
- Uses Manchester encoding, geographical limit is a few kilometers.

**10Base5 Thick Ethernet** :: thick (10 mm) coax  
10 Mbps, 500 m. max segment length, 100 devices/segment, awkward to handle and install.

**10Base2 Thin Ethernet** :: thin (5 mm) coax  
10 Mbps, 185 m. max segment length, 30 devices/segment, easier to handle, uses T-shaped connectors.

# Broadband Coax

- 75-ohm cable (CATV system standard).
- Used for both analog and digital signaling.
- Analog signaling - frequencies up to 500 MHz are possible.
- When FDM used, referred to as **broadband**.
- For long-distance transmission of analog signals, amplifiers are needed every few kilometers.



# Hybrid Fiber-Coaxial System

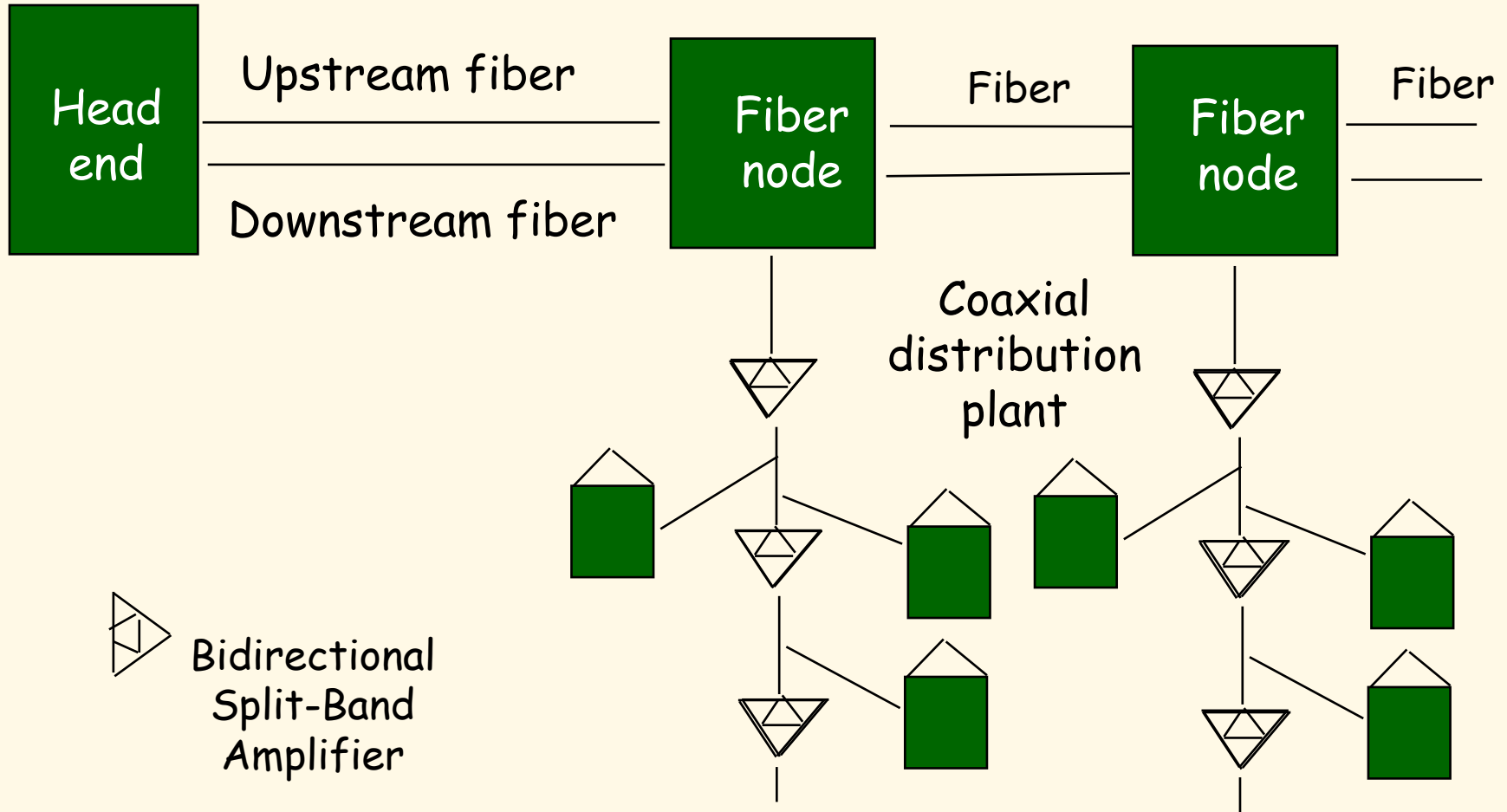

Leon-Garcia & Widjaja:  
*Communication Networks*

# Residential Access: Cable Modems

- Does not use telephone infrastructure.
  - Instead uses cable TV infrastructure.
- **HFC: Hybrid Fiber Coax**
  - asymmetric: up to 30Mbps downstream, 2 Mbps upstream
- A **network** of cable and fiber attaches homes to ISP router.
  - homes **share access** to router.
  - unlike DSL, which provides **dedicated access**.

K & R

# Residential Access: Cable Modems

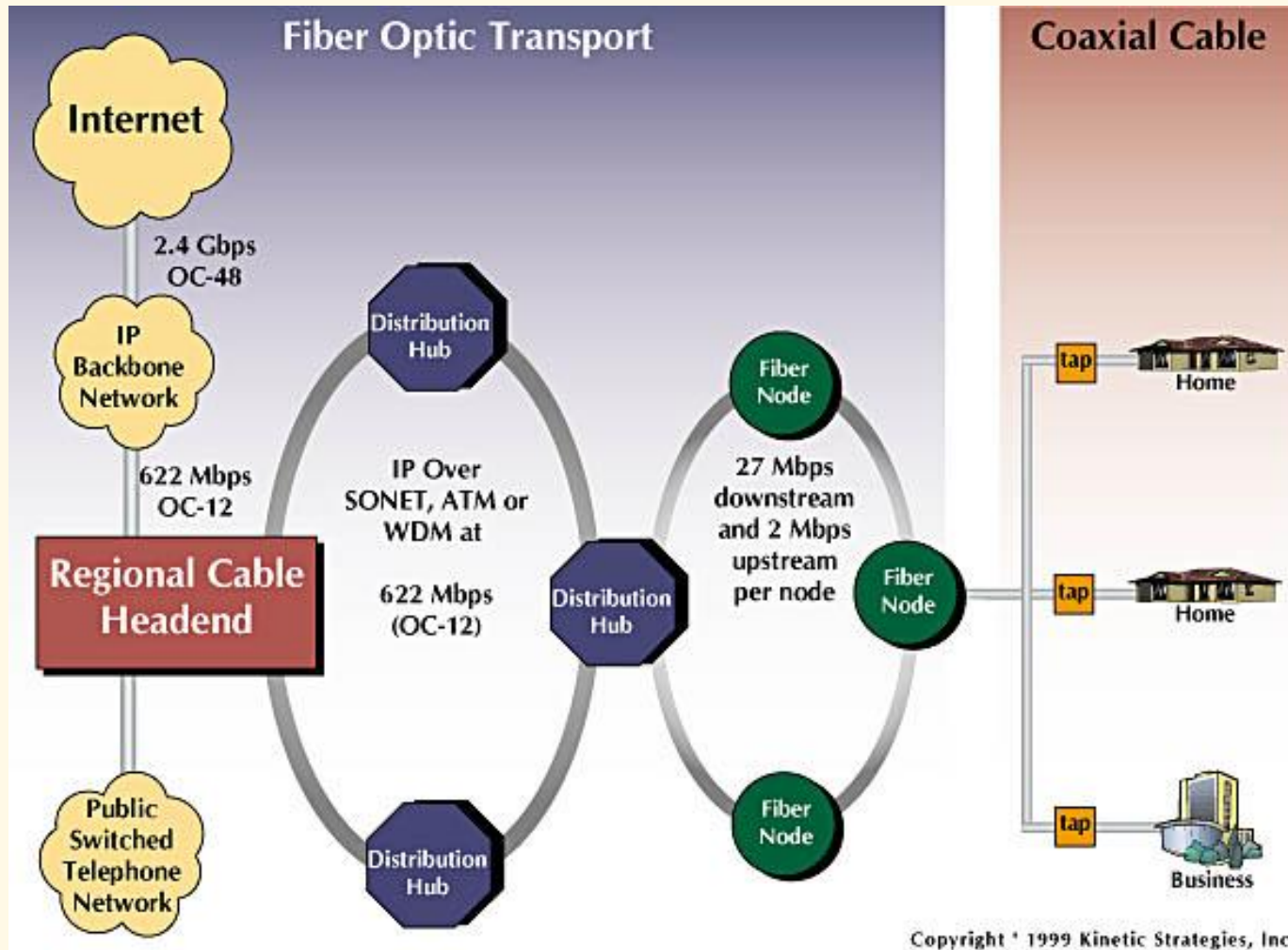
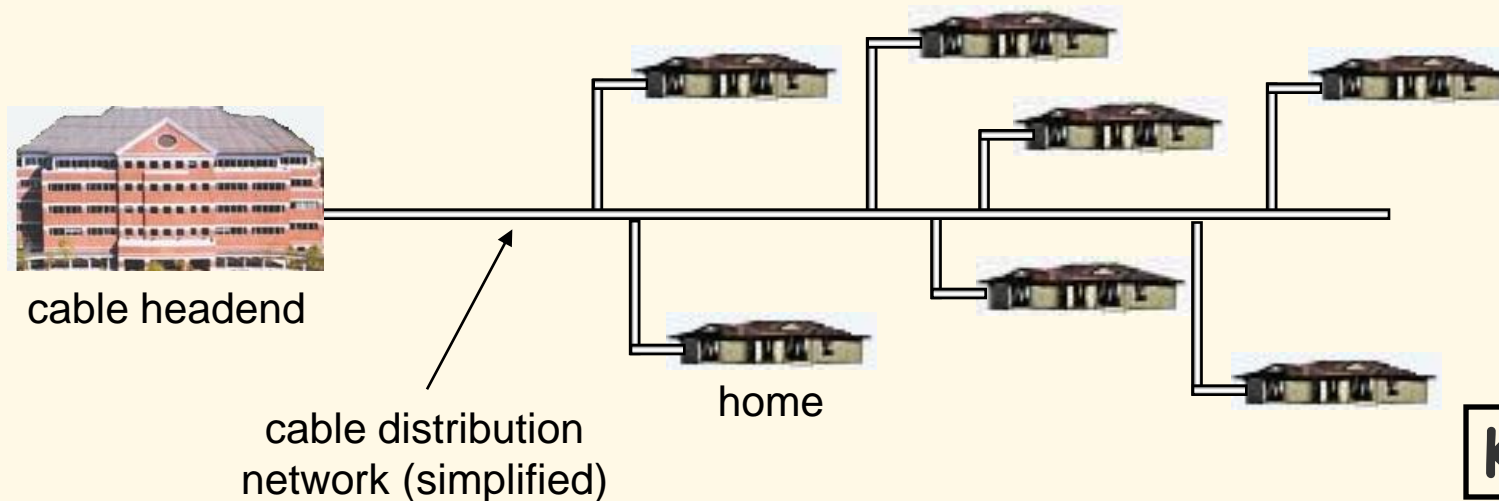

Diagram: <http://www.cabledatcomnews.com/cm/c/diagram.html>

K & R

# Cable Network Architecture: Overview

Typically 500 to 5,000 homes



K & R

# Cable Network Architecture: Overview

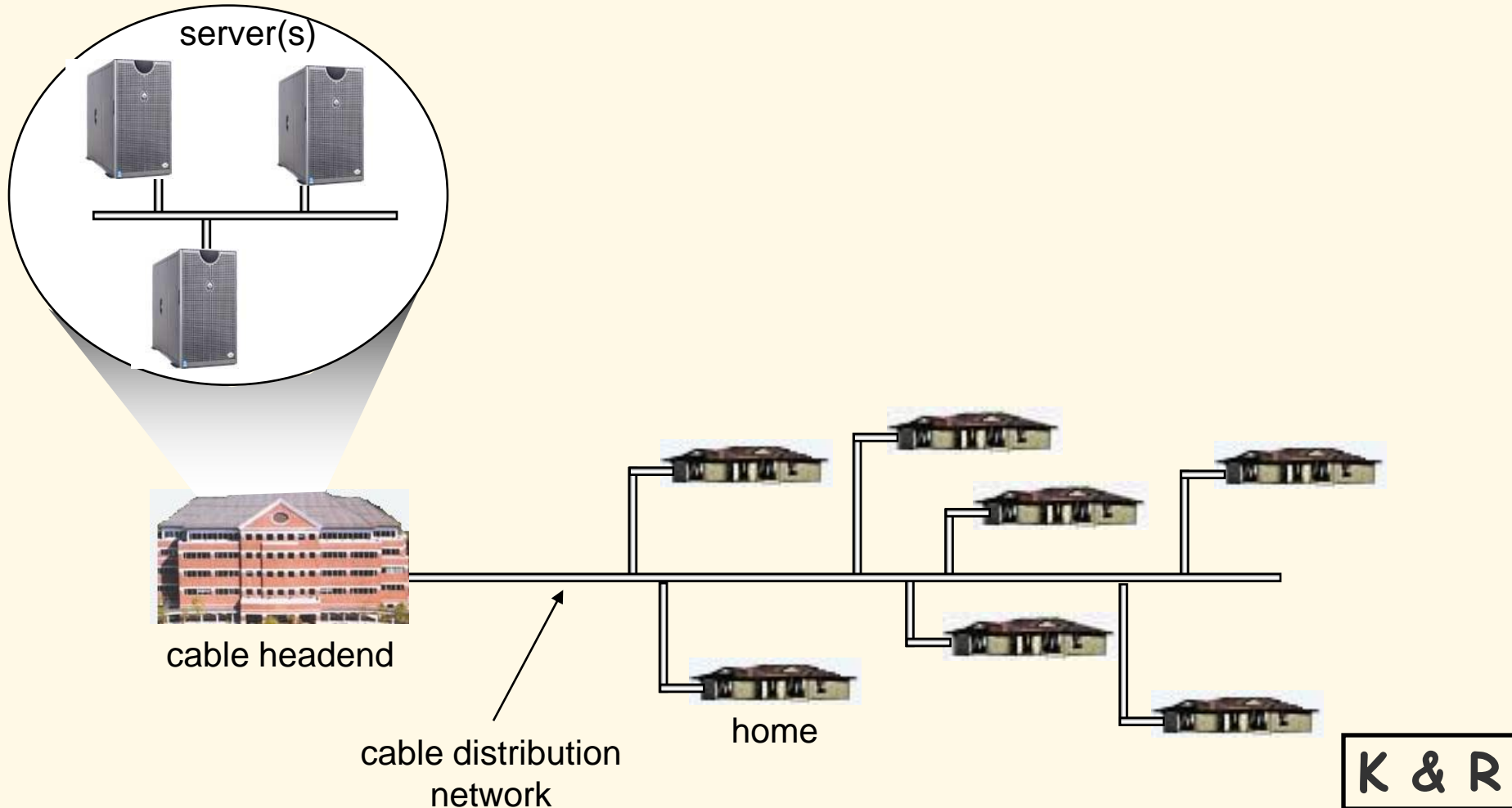

K & R

# Cable Network Architecture: Overview

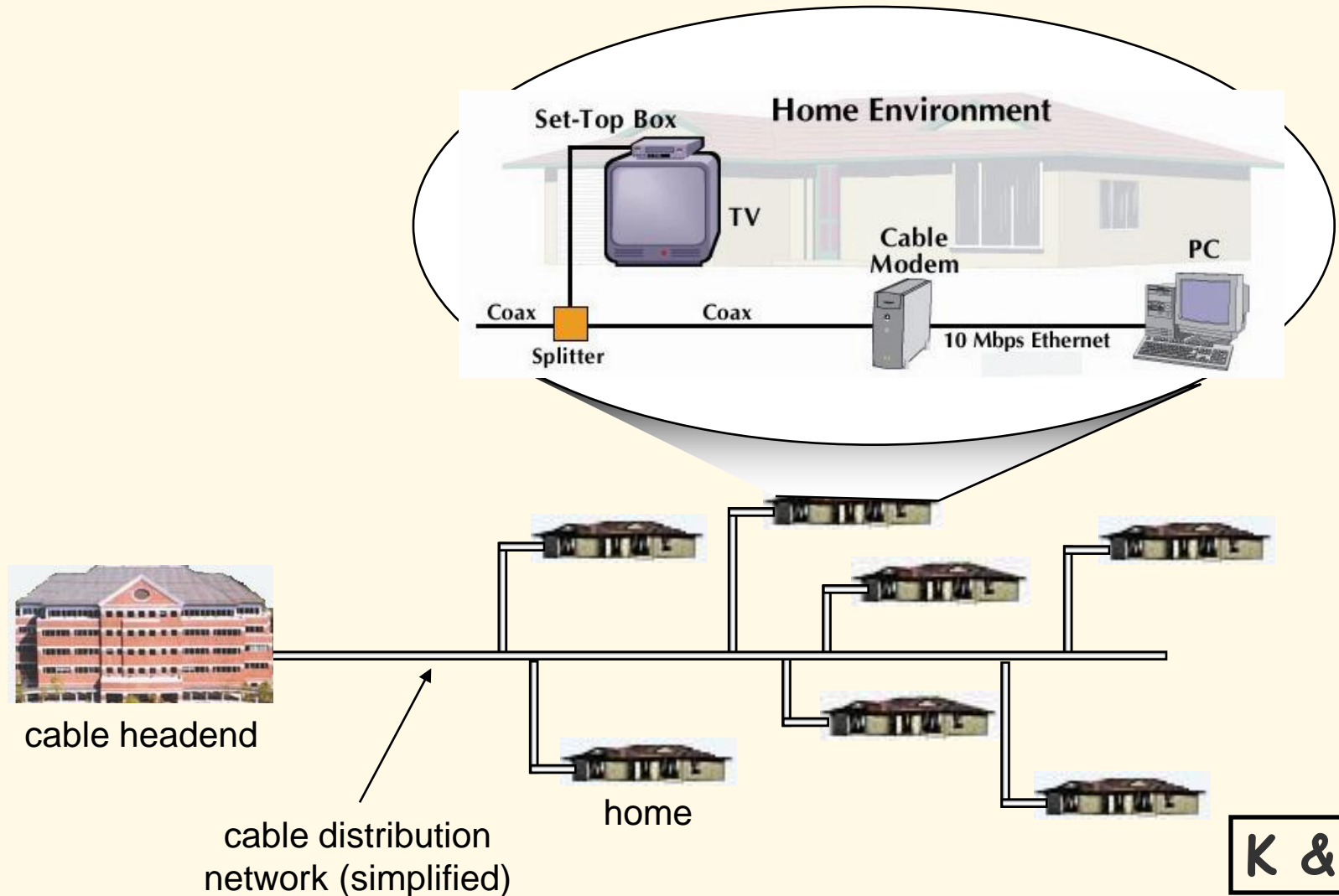

K & R

# Cable Network Architecture: Overview

FDM (more shortly):

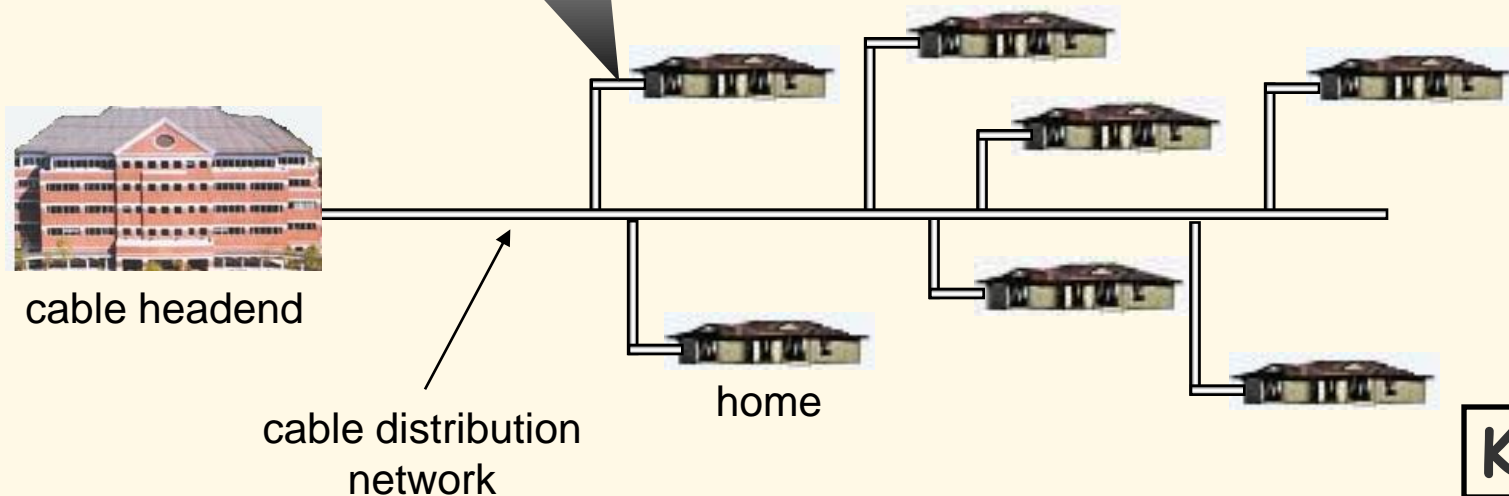
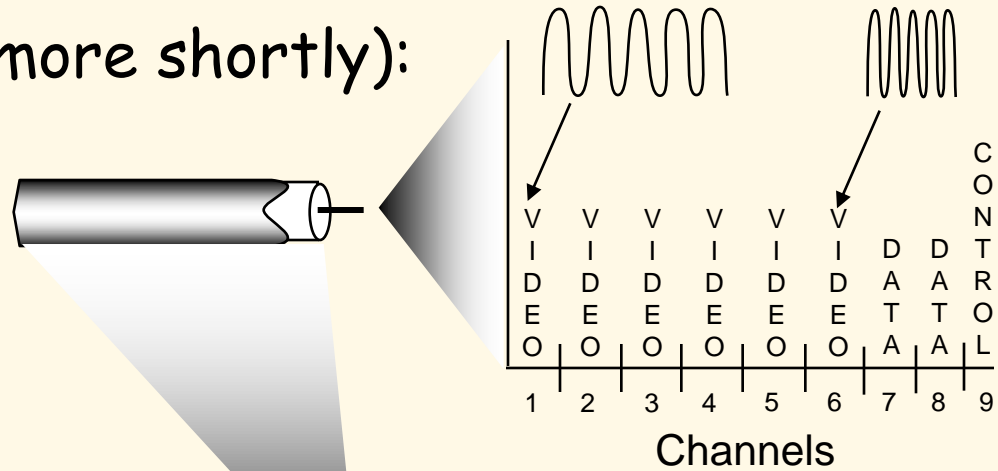

K & R

# Optical Fiber

- **Optical fiber**:: a thin flexible medium capable of conducting optical rays. Optical fiber consists of a very fine cylinder of glass (core) surrounded by concentric layers of glass (cladding).
- a signal-encoded beam of light (a fluctuating beam) is transmitted by **total internal reflection**.
- Total internal reflection occurs in the core because it has a higher optical density (index of refraction) than the cladding.
- Attenuation in the fiber can be kept low by controlling the impurities in the glass.



# Optical Fiber

(a) Geometry of optical fiber

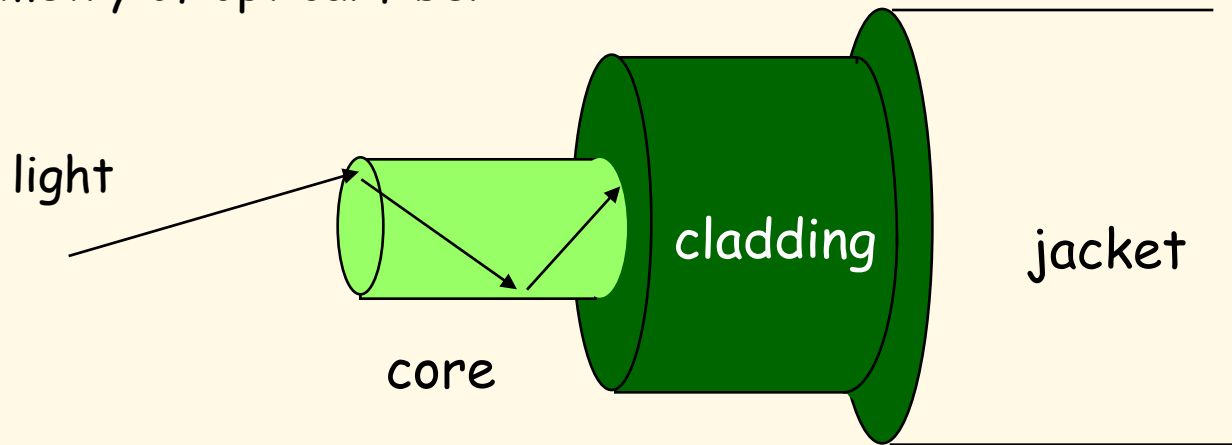

(b) Reflection in optical fiber

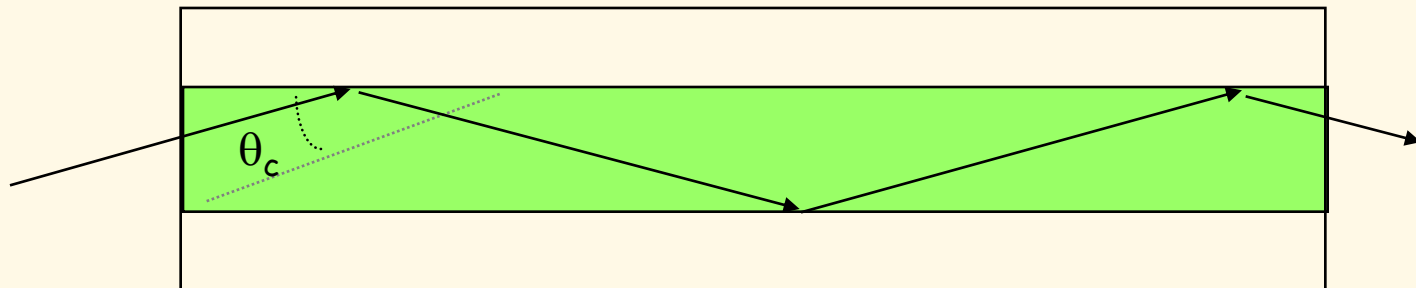

Leon-Garcia & Widjaja:  
*Communication Networks*

# Optical Fiber

- Lowest signal losses are for ultrapure fused silica - but this is hard to manufacture.
- Optical fiber acts as a **wavelength guide** for frequencies in the range  $10^{14}$  to  $10^{15}$  HZ which covers the visible and part of the infrared spectrum.
- Three standard wavelengths : 850 nanometers (nm.), 1300 nm, 1500 nm.
- *First-generation optical fiber* :: 850 nm, 10's Mbps using LED (light-emitting diode) sources.
- *Second and third generation optical fiber* :: 1300 and 1500 nm using ILD (injection laser diode) sources, gigabits/sec.

# Optical Fiber

- Attenuation loss is lower at higher wavelengths.
- There are two types of detectors used at the receiving end to convert light into electrical energy (photo diodes):
  - PIN detectors - less expensive, less sensitive
  - APD detectors
- ASK is commonly used to transmit digital data over optical fiber {referred to as intensity modulation}.

# Wavelength Division Multiplexing

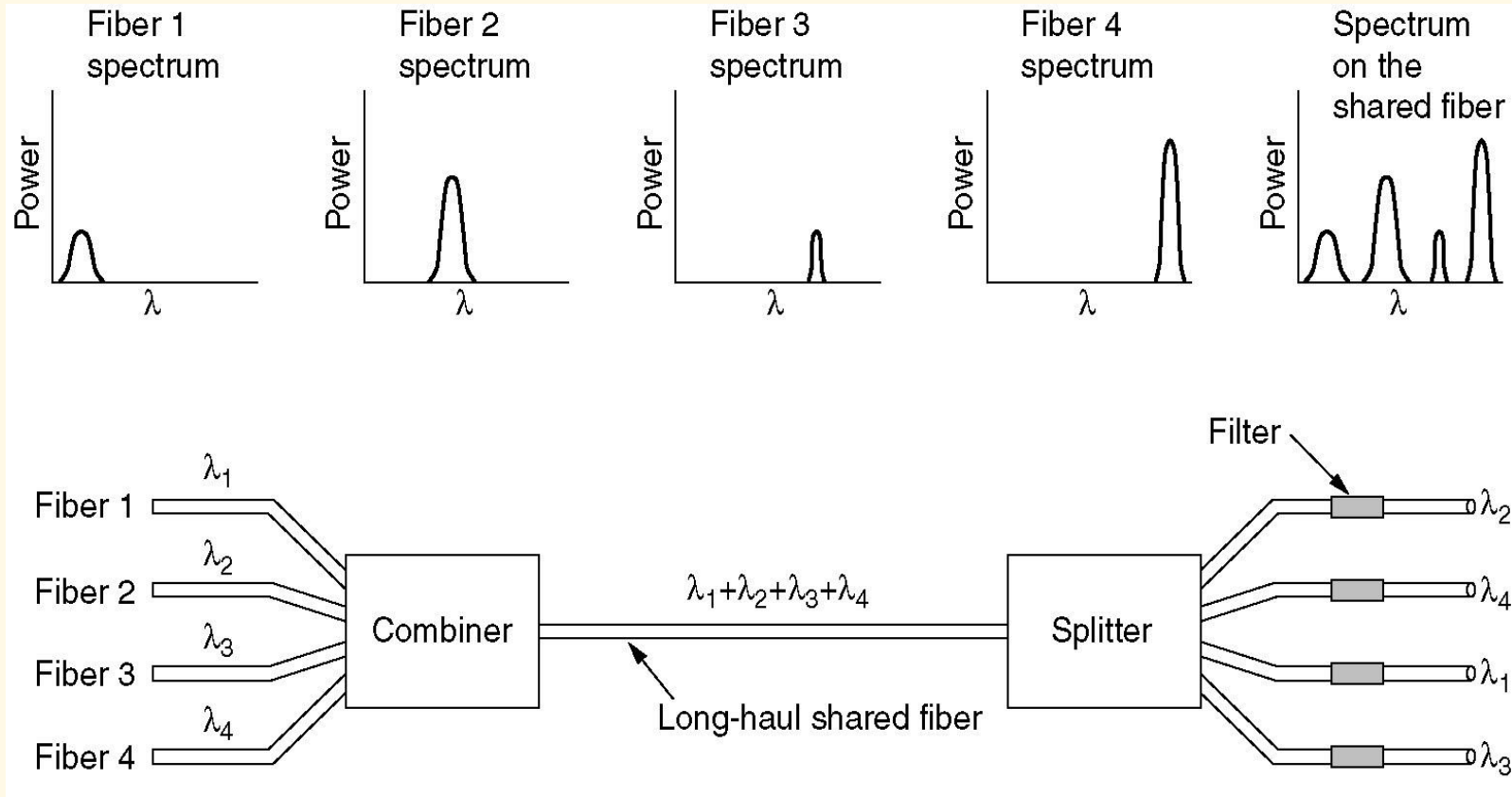

Figure 2-32.

Tanenbaum

# Optical Fiber

- Three techniques:
  - Multimode step-index
  - Multimode graded-index
  - Single-mode step-index
- Presence of multiple paths → differences in delay → optical rays *interfere* with each other.
- A **narrow core** can create a single direct path which yields higher speeds.
- WDM (Wavelength Division Multiplexing) yields more available capacity.

# Optical Fiber Transmission Modes

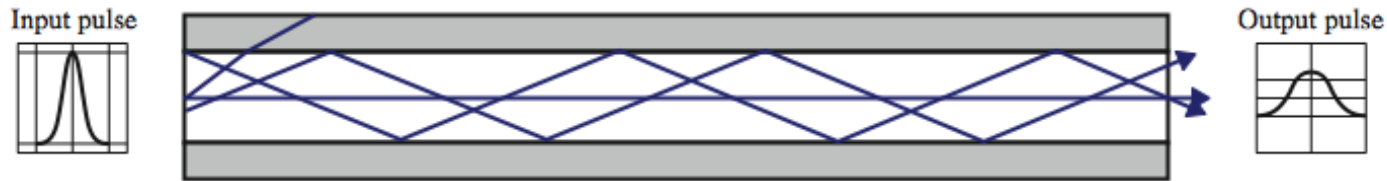

(a) Step-index multimode

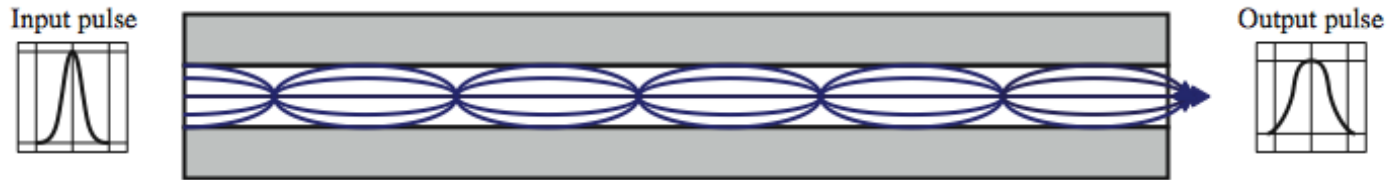

(b) Graded-index multimode

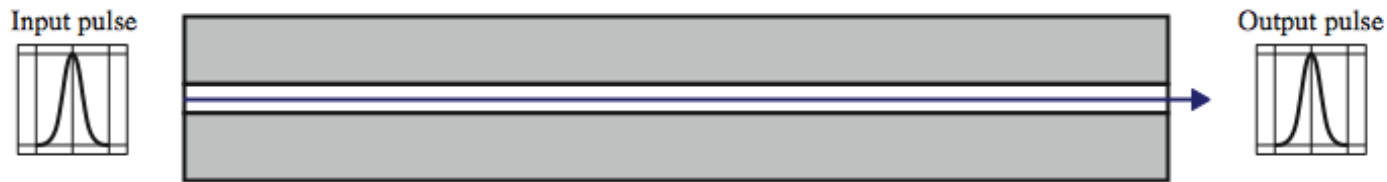

(c) Single mode

DCC 8<sup>th</sup> Ed.  
Stallings

# Frequency Utilization for Fiber Applications

Wavelength (in vacuum) range (nm)	Frequency Range (THz)	Band Label	Fiber Type	Application
820 to 900	366 to 333		Multimode	LAN
1280 to 1350	234 to 222	S	Single mode	Various
1528 to 1561	196 to 192	C	Single mode	WDM
1561 to 1620	192 to 185	L	Single mode	WDM

DCC 8<sup>th</sup> Ed.  
Stallings

# Fiber to the Home (FIOS)

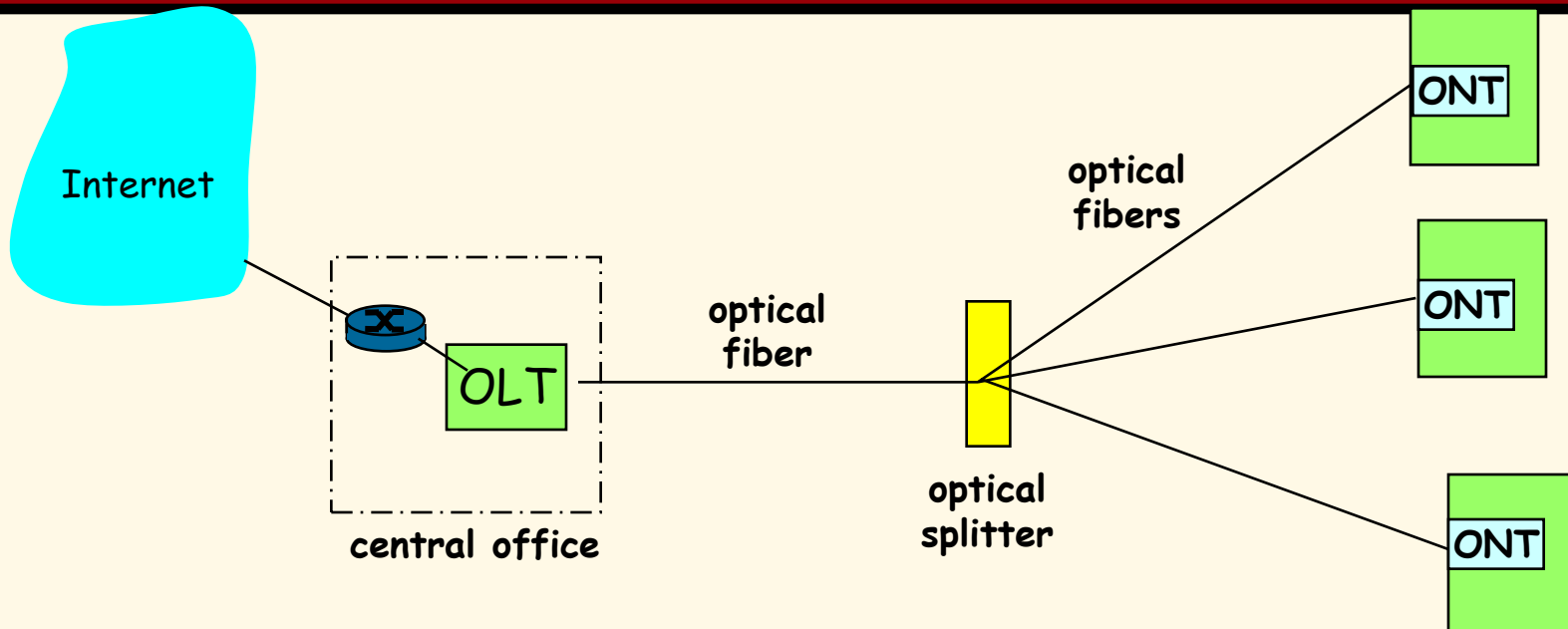

- Optical links from central office to the home
- Two competing optical technologies:
  - Passive Optical network (PON)
  - Active Optical Network (PAN)
- Much higher Internet rates. Fiber also carries television and phone services

K & R



# Wireless Communications (briefly)

- An application of omni-directional wireless communications to provide high-speed communications among a number of computers located in close proximity.
- In 1996 FCC in US announced its intentions to make 350 MHz of spectrum in the 5.15 to 5.35 GHz and 5.725 to 5.825 GHz bands available for unlicensed use in LAN applications.

# Telecommunications Spectrum

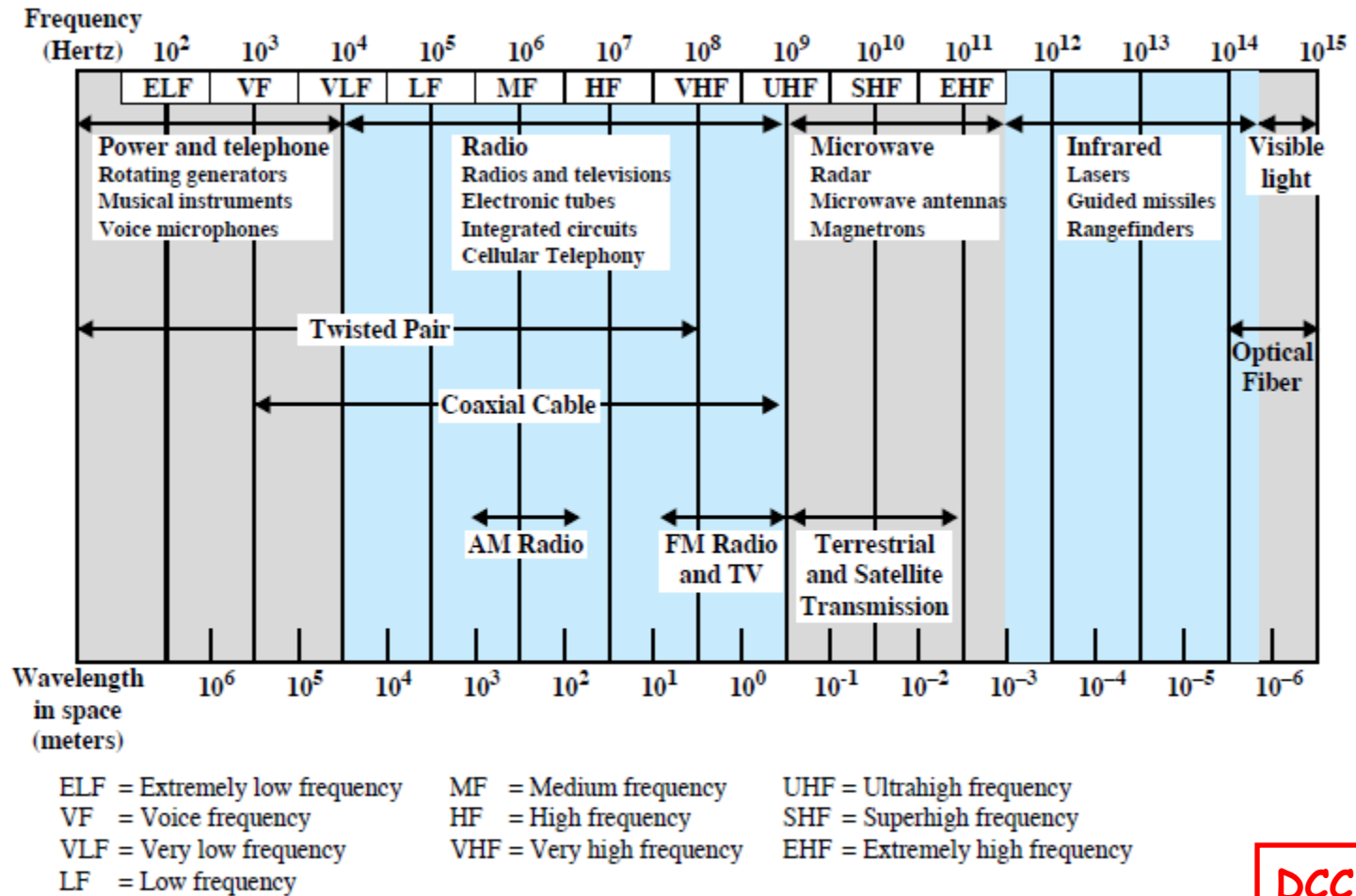
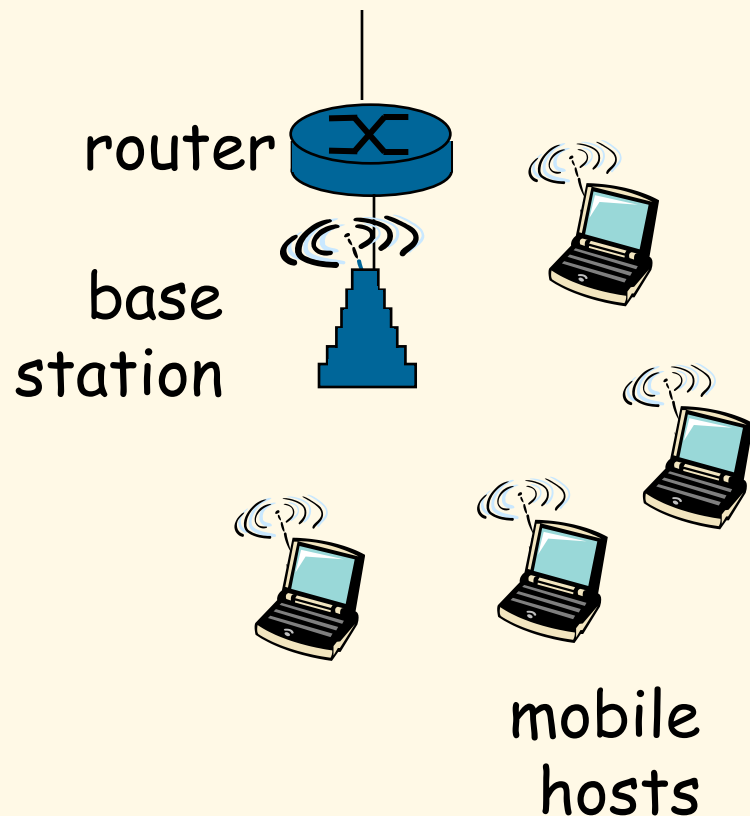

Figure 4.1 Electromagnetic Spectrum for Telecommunications

DCC 8<sup>th</sup> Ed.  
Stallings

# Wireless Access Networks

- shared *wireless* access network connects end system to router
  - via base station aka “access point”
- **Wireless LANs:**
  - 802.11b/g/n(WiFi): 11, 54, 100’s Mbps, Bluetooth, Zigbee (802.15.4)
- **Wide Area Wireless Access:**
  - provided by telco operator
  - ~1Mbps over cellular system (EVDO, HSDPA)
  - next up (?): WiMAX (10’s Mbps) over wide area



K & R

# Wireless Multipath Interference

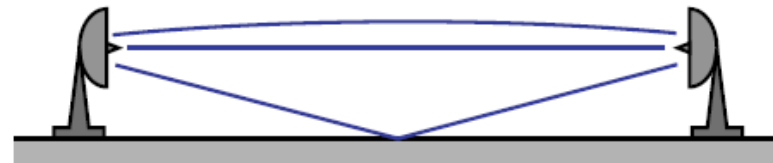

(a) Microwave line of sight

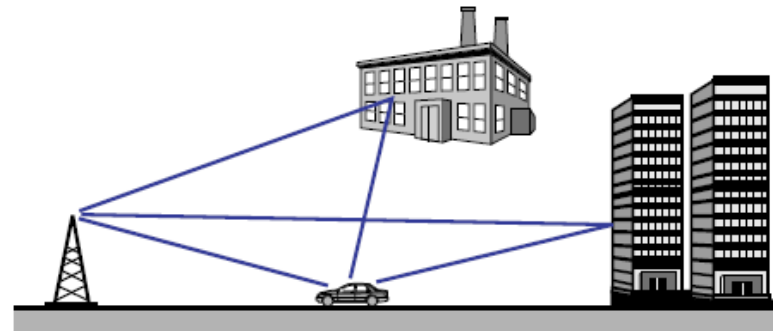

(b) Mobile radio

Figure 4.11 Examples of Multipath Interference

DCC 8<sup>th</sup> Ed.  
Stallings

# Residential Networks

## Typical Residential network components:

- DSL or cable modem
- Router/firewall/NAT
- Ethernet
- Wireless access point (AP)

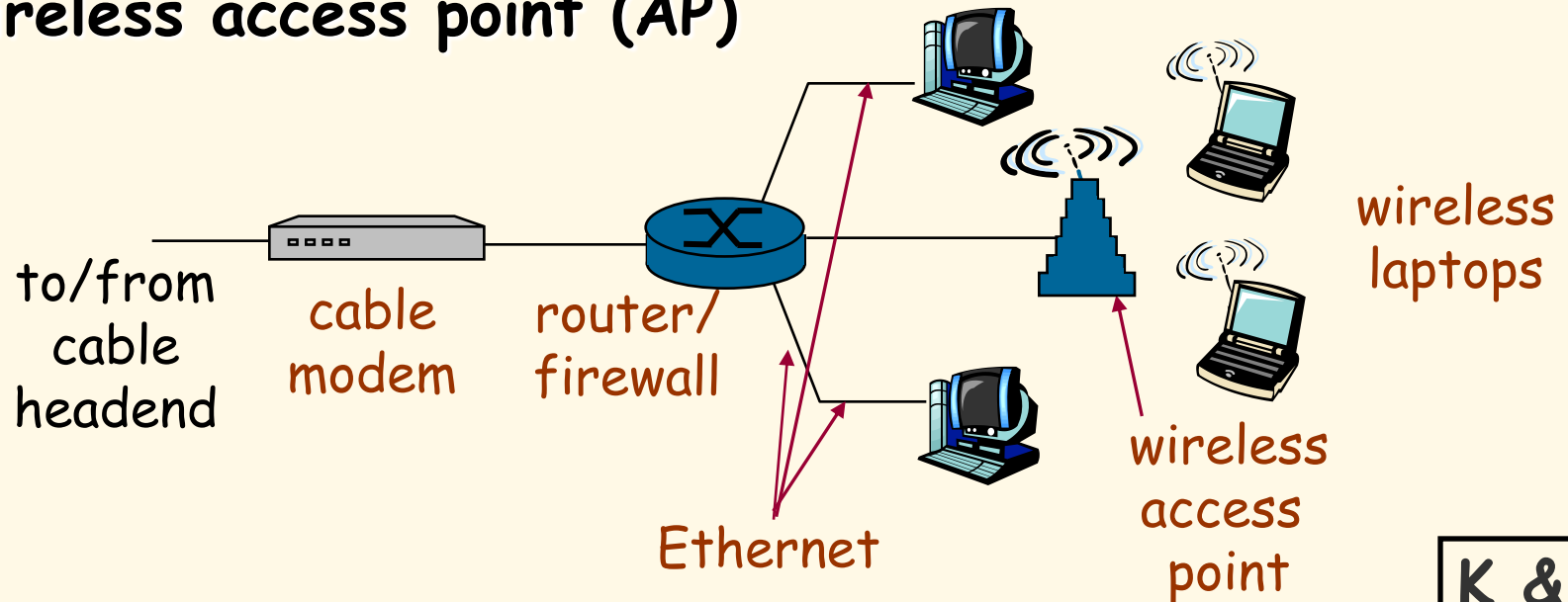

K & R

# Transmission Media Summary

## . Twisted pair

- Noise, interference and attenuation are issues.
- Cat5e modern required minimum (Fast Ethernet)
- Dial-Up and DSL (**ADSL**) Connections

## . Coaxial cable

- Baseband versus Broadband
- Cable is HFC (Hybrid Fiber-Coax)
- FDM and asymmetric channel capacities

# Transmission Media Summary

## . Optical Fiber

- Wavelength Division Multiplexing of light
- Very High Capacities
- Three standard wavelengths
- Three standard techniques
- Fiber to the home

## . Wireless Communications

- 'crowded' frequency spectrum
- WLAN and Wide Area wireless
- Common Residential 'Last Hop' to the Internet involves wireless AP (router, firewall, NAT).