

Wireless Sensor Networks (WSNs)



Internet of Things
Fall 2015

WSN Outline

- **Introduction**
- **Mote Revolution**
- **Wireless Sensor Network (WSN) Applications**
- **WSN Details**
- **Types of Wireless Sensor Networks (WSNs)**
 - Tiered Architectures
- **Dynamic Cluster Formation**
- **Power-Aware MAC Protocols**
 - S-MAC, T-MAC, LPL, X-MAC
- **The Internet of Things**

Wireless Sensor Networks

- A distributed connection of nodes that coordinate to perform a common task.
- In many applications, the nodes are **battery powered** and it is often very difficult to recharge or change the batteries.
- Prolonging **network lifetime** is a critical issue.
- Sensors often have long period between transmissions (e.g., in seconds).
- Thus, a good WSN MAC protocol needs to be **energy efficient**.

WSN Outline

- Introduction
- **Mote Revolution**
- Wireless Sensor Network (WSN) Applications
- WSN Details
- Types of Wireless Sensor Networks (WSNs)
 - Tiered Architectures
- Dynamic Cluster Formation
- Power-Aware MAC Protocols
 - S-MAC, T-MAC, LPL, X-MAC
- The Internet of Things

WSN Outline

- Introduction
- Mote Revolution
- **Wireless Sensor Network (WSN) Applications**
- WSN Details
- Types of Wireless Sensor Networks (WSNs)
 - Tiered Architectures
- Dynamic Cluster Formation
- Power-Aware MAC Protocols
 - S-MAC, T-MAC, LPL, X-MAC
- The Internet of Things

WSN Applications

- **Environmental/ Habitat Monitoring**
 - **Scientific, ecological applications**
 - Non-intrusiveness
 - Real-time, high spatial-temporal resolution
 - Remote, hard-to-access areas
 - **Acoustic detection**
 - **Seismic detection**
- **Surveillance and Tracking**
 - **Military and disaster applications**
 - **Reconnaissance and Perimeter control**
 - **Structural monitoring (e.g., bridges)**

WSN Applications

- **“Smart” Environments**
 - Precision Agriculture
 - Manufacturing/Industrial processes
 - Inventory (RFID)
 - Process Control
 - Smart Grid
- **Medical Applications**
 - Hospital/Clinic settings
 - Retirement/Assisted Living settings

Environment Monitoring

Great Duck Island



- 150 sensing nodes deployed throughout the island relay data temperature, pressure, and humidity to a central device.
- Data was made available on the Internet through a satellite link.

Habitat Monitoring

The ZebraNet Project

- Collar-mounted sensors with GPS
- Use peer-to peer info communication
- monitor zebra movement in Kenya



Margaret Martonosi
Princeton University

FireBug

[Nuwan Gajaweera]

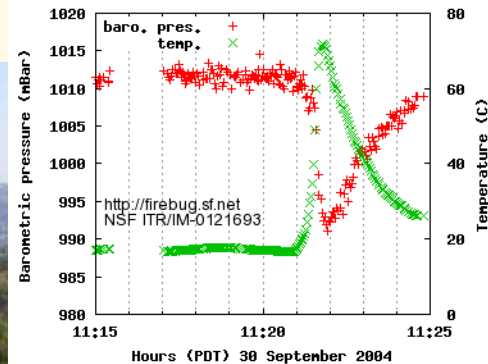
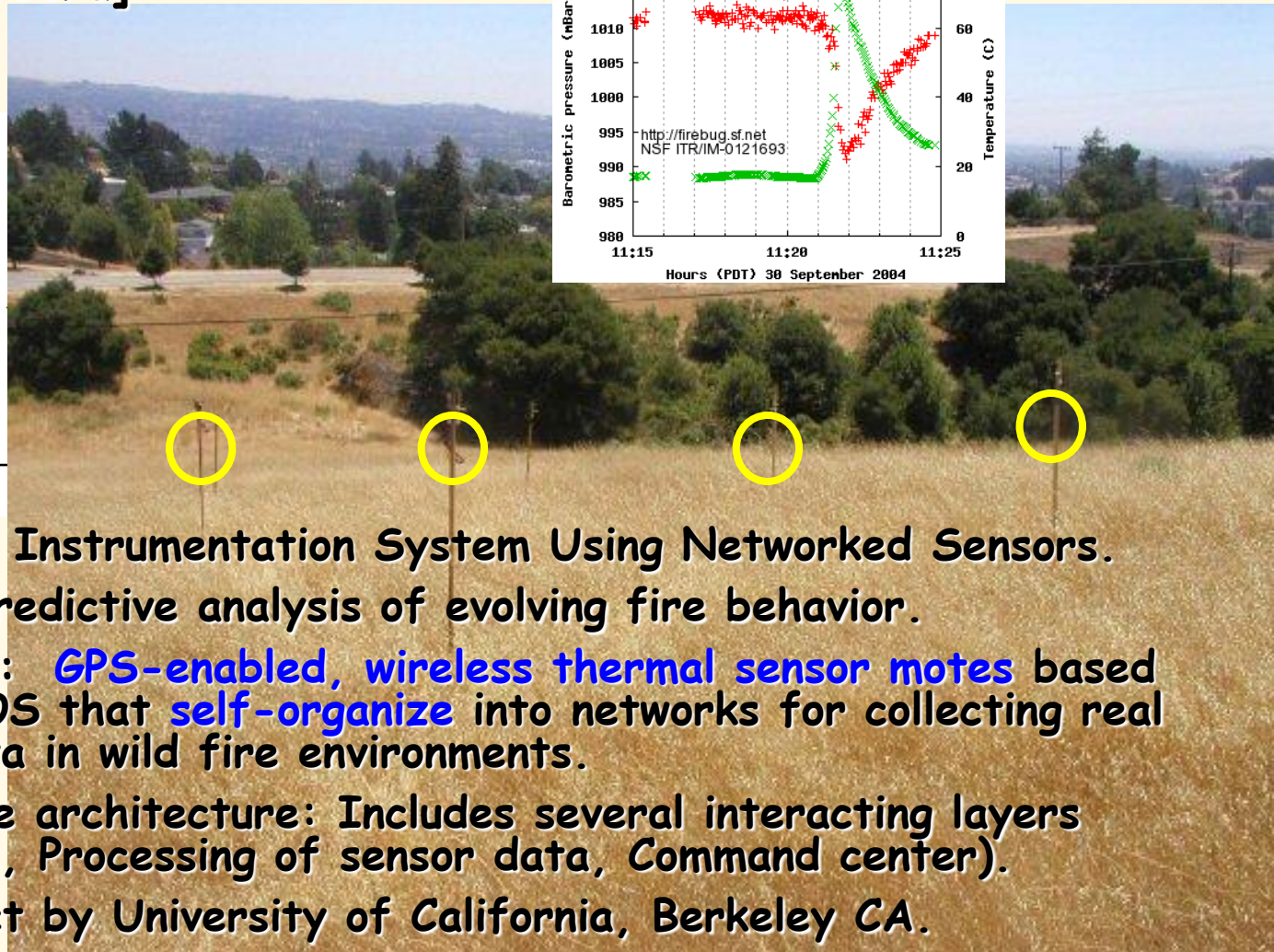
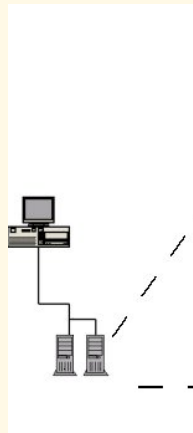

- Wildfire Instrumentation System Using Networked Sensors.
- Allows predictive analysis of evolving fire behavior.
- Firebugs: **GPS-enabled, wireless thermal sensor motes** based on TinyOS that **self-organize** into networks for collecting real time data in wild fire environments.
- Software architecture: Includes several interacting layers (Sensors, Processing of sensor data, Command center).
- A project by University of California, Berkeley CA.

Precision Agriculture

- The “Wireless Vineyard”
 - Sensors monitor temperature, moisture
 - Roger the dog collects the data



Richard Beckwith
Intel Corporation

Camalie Vineyards

Case Study in Crossbow Mote Deployment



Copyright 2006 Camalie Vineyards, Not to be reproduced without written permission

Water in the Vineyard



Vineyard Installation



- At each Mote location:
 - 2 soil moisture sensors
 - 12” and 24” depth
 - 1 soil temp sensor to calibrate soil moisture sensors



Power Supply

- 2 month max battery life now with 10 minute sampling interval.
- Decided to use solar power, always there when doing irrigation. Solar cell \$10 in small quantities and need a \$.50 regulator.

Network Maps

13 nodes late 2005, 18 nodes in 2006

Irrigation Block Map

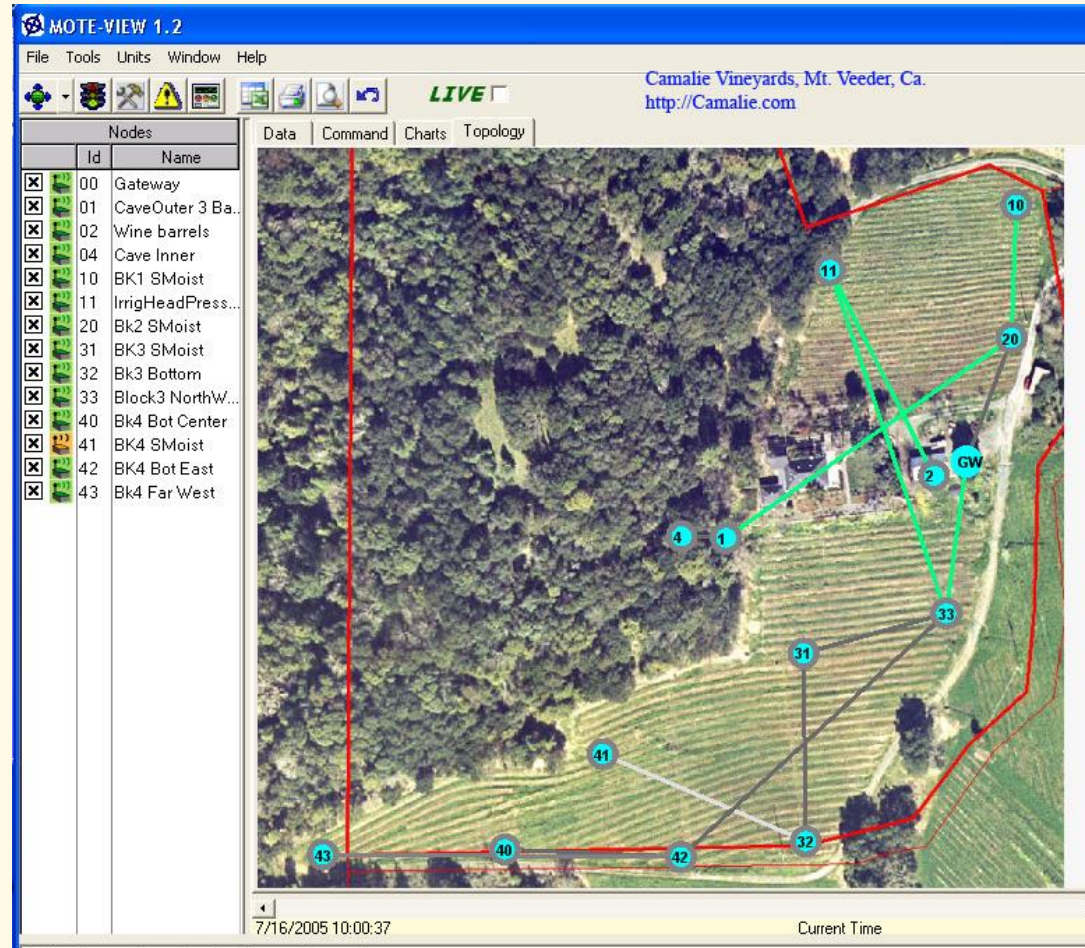
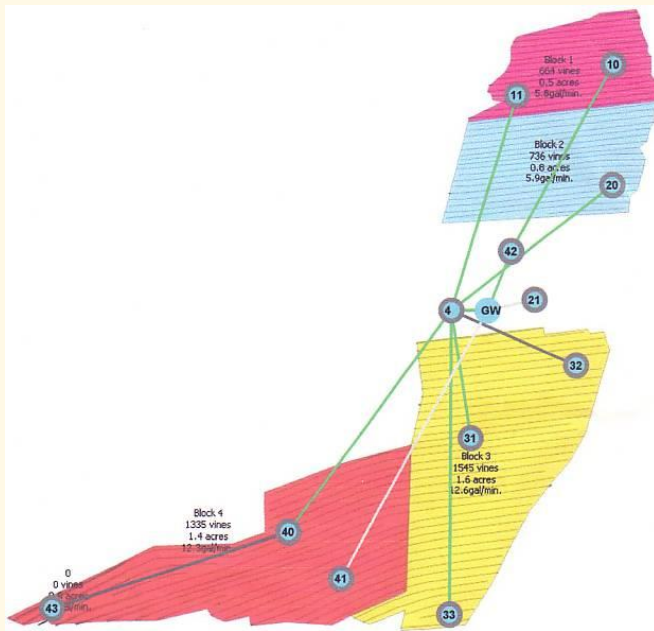

A Vision for Wireless MIS

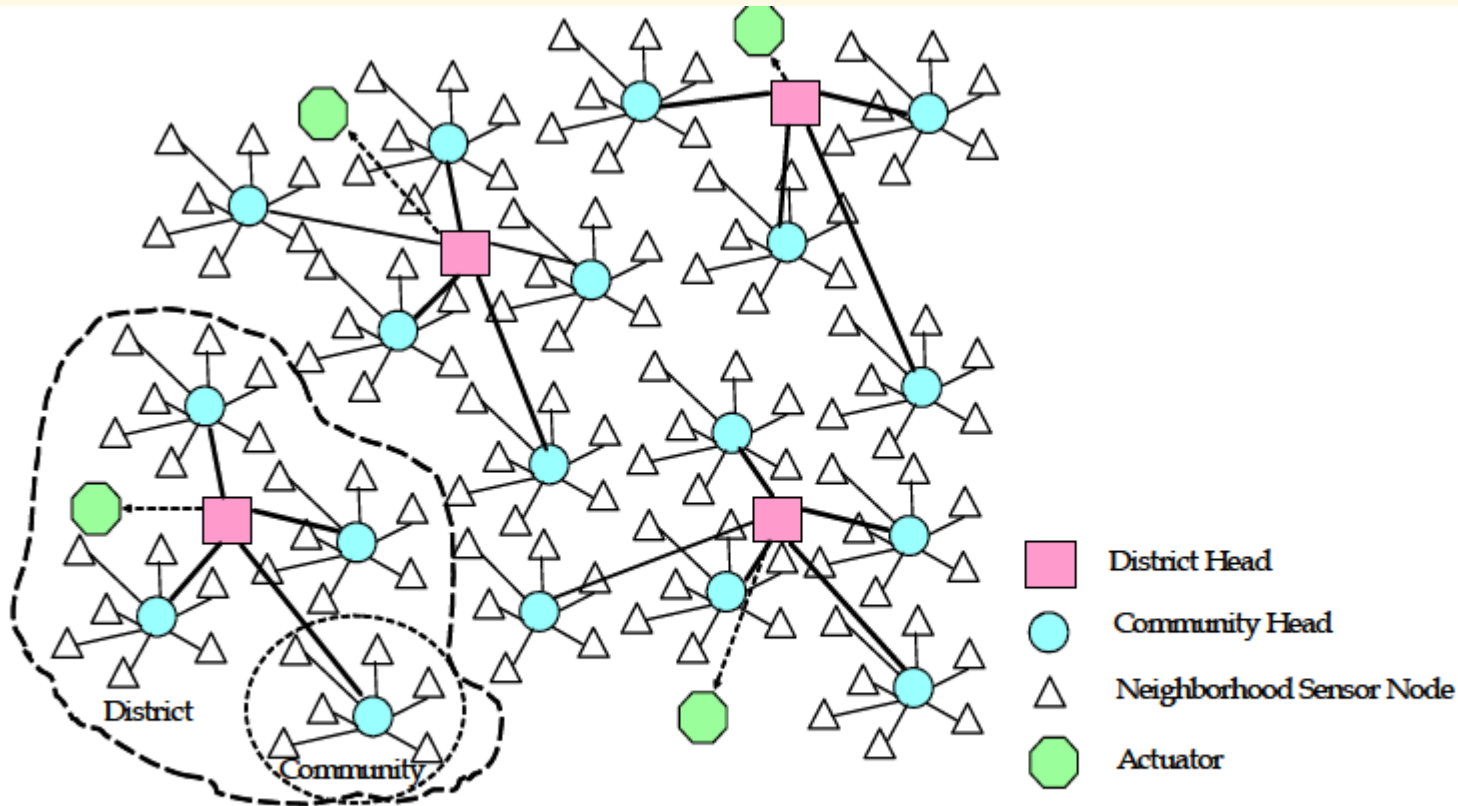

Figure 1 Hierarchical Scalable Sensor Network Architecture

[DS-MAC]

**Concept includes smart phone platforms
to streamline continuous monitoring.**

A Vision for Wireless MIS

Community head: In-body sensor node that communicates with the outside world, and is in direct communication range from other in-body sensors. Community head node is dynamically selected and rotated.

Hierarchy 1: In-body sensors form a 1-hop ad-hoc community network. Can operate in unused 412 MHz spectrum with 802.11e based QoS MAC protocol

Hierarchy 2: Inter-person communication (district network). Medical data diffusion to central processing facilities using the same band and protocols as the in-body network

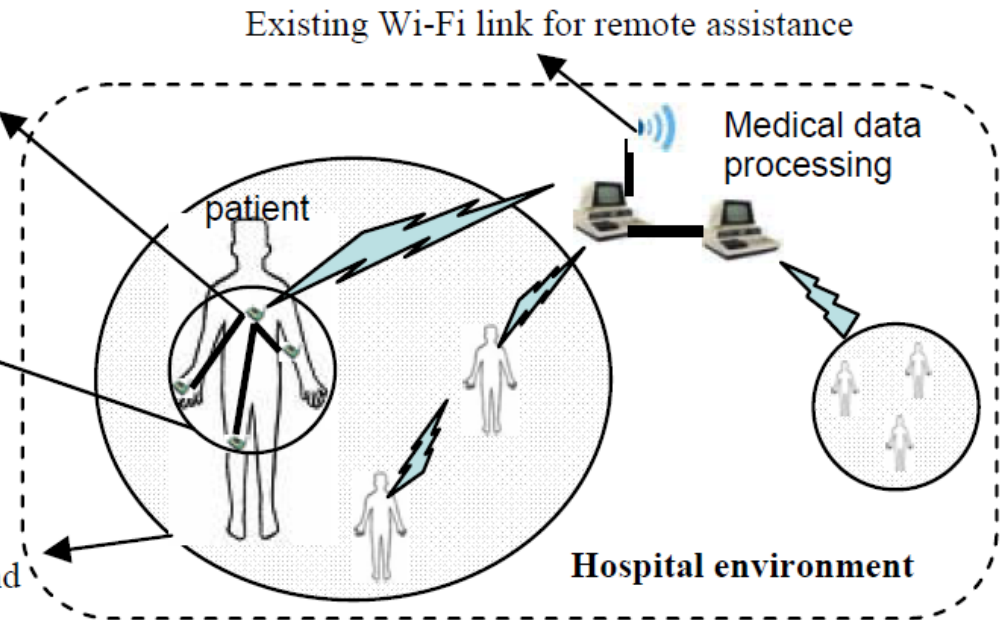

Figure 2: Medical Information System Architecture in Hospital Environment [DS-MAC]

Health surveillance region provides a multi-hop path from body sensor networks to central data log and processing nodes.

WSNs for Assisted Living

Alarm-Net
University of Virginia

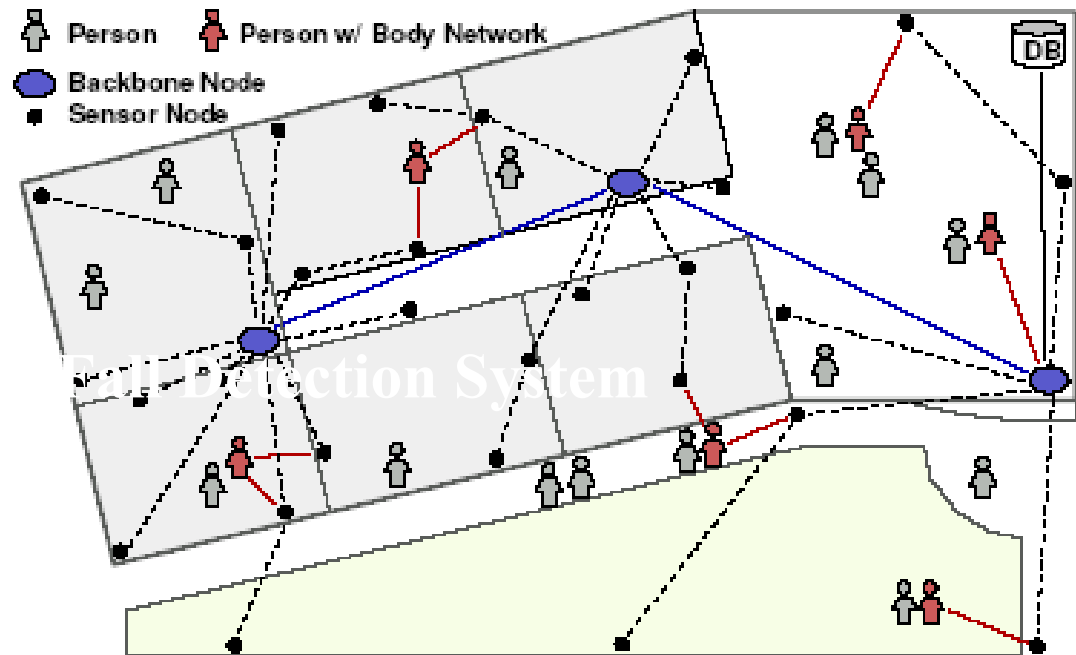

Figure 1. Assisted-living deployment example, showing connections among sensors, body networks, and backbone nodes.

WSNs for Assisted Living

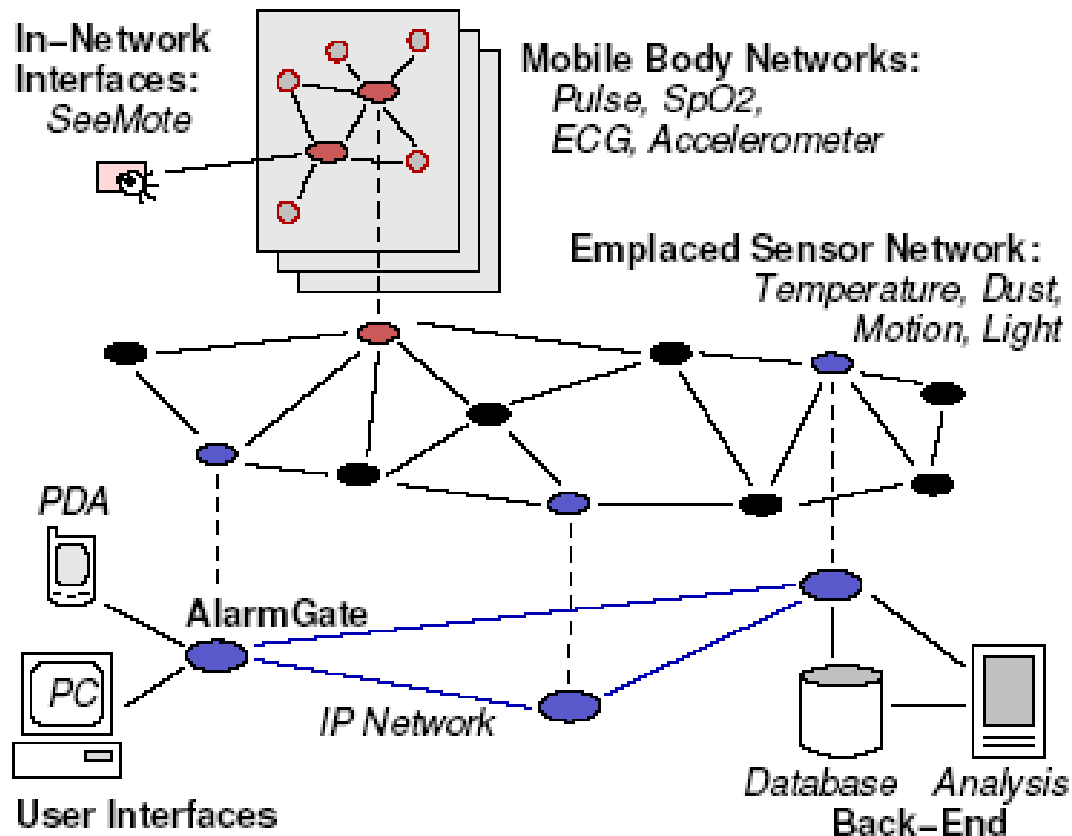

Figure 2. ALARM-NET architecture components and logical topology.

WSNs for Assisted Living

Two-Tiered
WSN
Architecture

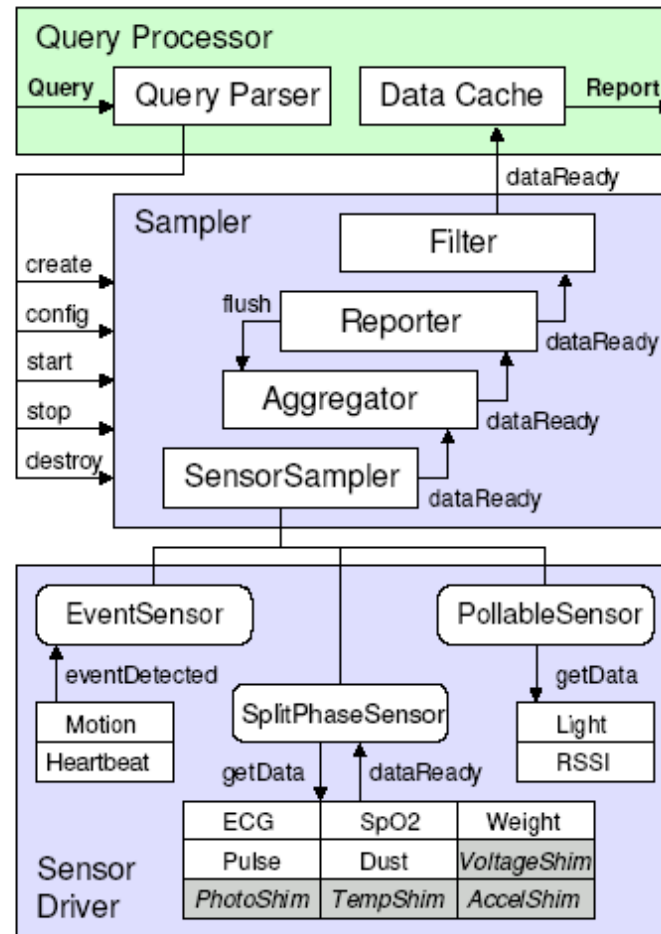

Figure 3. Query processing stack on sensor devices. The Query Processor parses queries, and starts the Sampler, which reads data from the sensor drivers on schedule, generating data that flows up the processing chain toward the Query Processor for reporting.

Berkeley Fall Detection System

USING SMART SENSORS AND A CAMERA PHONE TO DETECT AND VERIFY THE FALL OF ELDERLY PERSONS

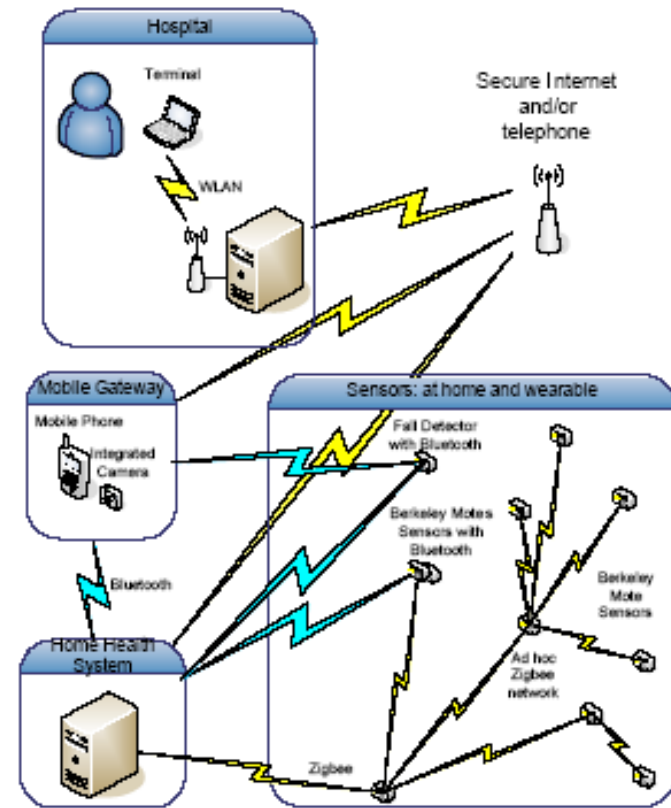

Figure 1: The Information Technology for Assisted Living at Home (ITALH) system overview

Berkeley Fall Detection System

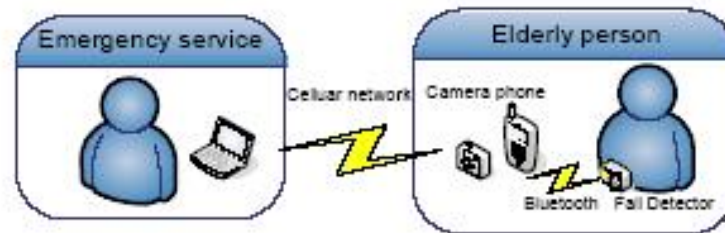

Figure 2: Fall detector system setup



Figure 3: The Berkeley GPSADXL fall sensor

WSN Outline

- Introduction
- Mote Revolution
- Wireless Sensor Network (WSN) Applications
- **WSN Details**
- Types of Wireless Sensor Networks (WSNs)
 - Tiered Architectures
- Dynamic Cluster Formation
- Power-Aware MAC Protocols
 - S-MAC, T-MAC, LPL, X-MAC
- The Internet of Things

Wireless Sensor Networks

- Another attribute is **scalability and adaptability to change** in network size, node density and topology.
 - In general, nodes can die, join later or be mobile.
- Often high bandwidth is **not important**.
- Nodes can take advantage of short-range, multi-hop communication to conserve energy.

Wireless Sensor Networks

- Sources of energy waste:
 - Idle listening, collisions, overhearing and control overhead and **overmitting**.
 - Idle listening dominates (measurements show idle listening consumes between 50-100% of the energy required for receiving.)

Idle listening:: listen to receive possible traffic that is not sent.

Overmitting:: transmission of message when receiver is not ready.

Power Measurements

Symbol	Meaning	CC1000	CC2420
P_{tx}	Power in transmitting	31.2mW	52.2mW
P_{rx}	Power in receiving	22.2mW	56.4mW
P_{listen}	Power in listening	22.2mW	56.4mW
P_{sleep}	Power in sleeping	$3\mu\text{W}$	$3\mu\text{W}$
P_{poll}	Power in channel polling	7.4mW	12.3mW
t_{pl}	Avg. time to poll channel	3ms	2.5ms
t_{csl}	Avg. carrier sense time	7ms	2ms
t_B	Time to Tx/Rx a byte	$416\mu\text{s}$	$32\mu\text{s}$
T_p	Channel polling period	Varying	Varying
T_{data}	Data packet period	Varying	Varying
r_{data}	Data packet rate ($1/T_{data}$)	Varying	Varying
L_{data}	Data packet length	50B	50B
n	Number of neighbors	10	10

Table 1. Symbols used in radio energy analysis, and typical values for the Mica2 radio (CC1000) and an 802.15.4 radio (CC2420)

WSN Communication Patterns

- **Broadcast::** e.g., Base station transmits to all sensor nodes in WSN.
- **Multicast::** sensor transmit to a subset of sensors (e.g. cluster head to cluster nodes)
- **Convergecast::** when a group of sensors communicate to one sensor (BS, cluster head, or data fusion center).
- **Local Gossip::** sensor sends message to neighbor sensors.

Wireless Sensor Networks

- **Duty cycle:: ratio between listen time and the full listen-sleep cycle.**
- **central approach - lower the duty cycle by turning the radio off part of the time.**
- **Three techniques to reduce the duty cycle:**
 - TDMA
 - Scheduled contention periods
 - LPL (Low Power Listening)

Techniques to Reduce Idle Listening

- **TDMA** requires cluster-based or centralized control.
- **Scheduling** - ensures short listen period when transmitters and listeners can rendezvous and other periods where nodes sleep (turn off their radios).
- **LPL** - nodes wake up briefly to check for channel activity without receiving data.
 - If channel is idle, node goes back to sleep.
 - If channel is busy, node stays awake to receive data.
 - A long preamble (longer than poll period) is used to assure than preamble intersects with polls.

WSN Outline

- Introduction
- Mote Revolution
- Wireless Sensor Network (WSN) Applications
- WSN Details
- **Types of Wireless Sensor Networks (WSNs)**
 - Tiered Architectures
- Dynamic Cluster Formation
- Power-Aware MAC Protocols
 - S-MAC, T-MAC, LPL, X-MAC
- The Internet of Things

Tree Routing

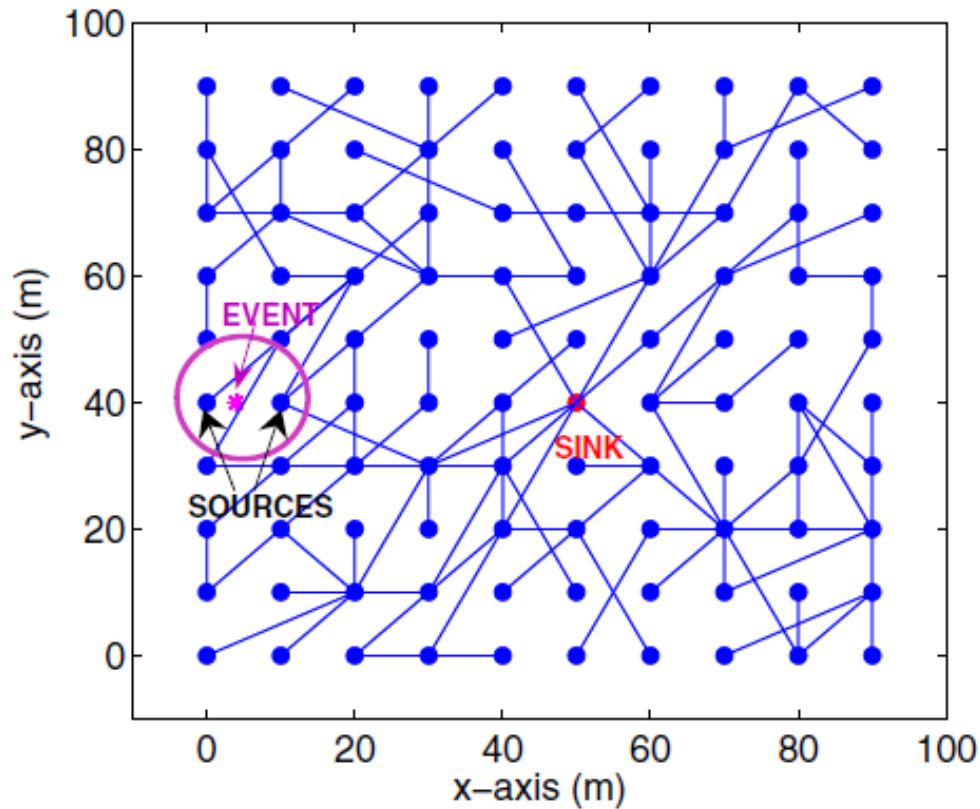

Fig. 1. Simulation scenario: black points represent sensor nodes and edges correspond to *parent-child relationships*

[Cuomo]

Tiered WSN Architectures

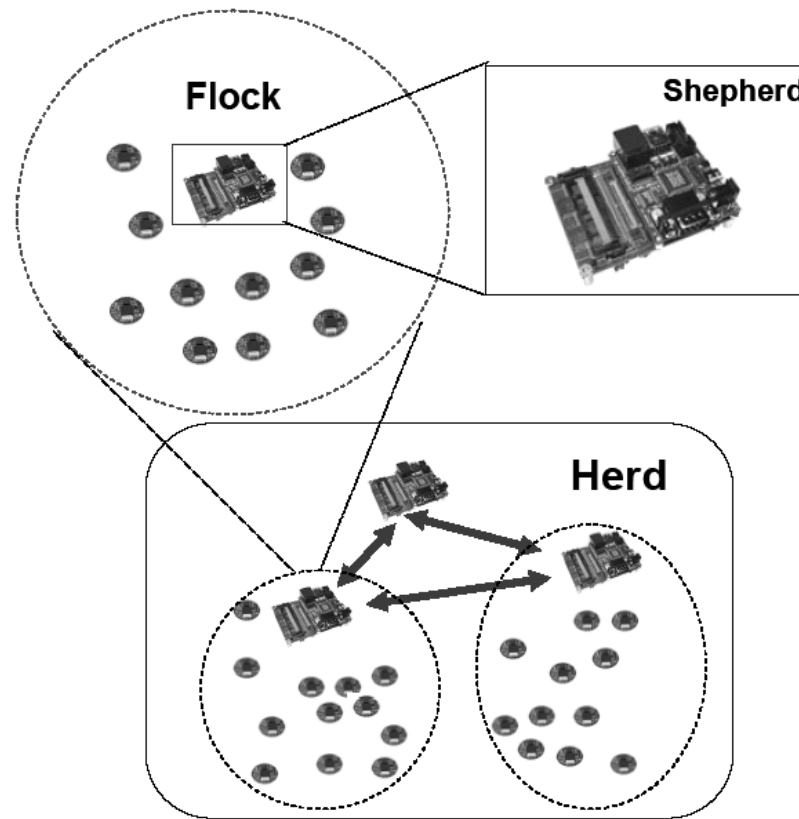

Figure 1: The Mote Herding architecture and its components, the *flock*, the *shepherd* and the *herd* [Stathopoulos]

Dynamic Cluster Formation



Wireless Sensor Networks

Choosing Cluster Heads/ Forming Clusters

Two-tier scheme:

- A **fixed number of cluster heads** that communicate with BS (base station).
- Nodes in cluster communicate with head (normally TDMA).
- TDMA allows **fixed schedule of slots** for sensor to send to cluster head and receive head transmissions.

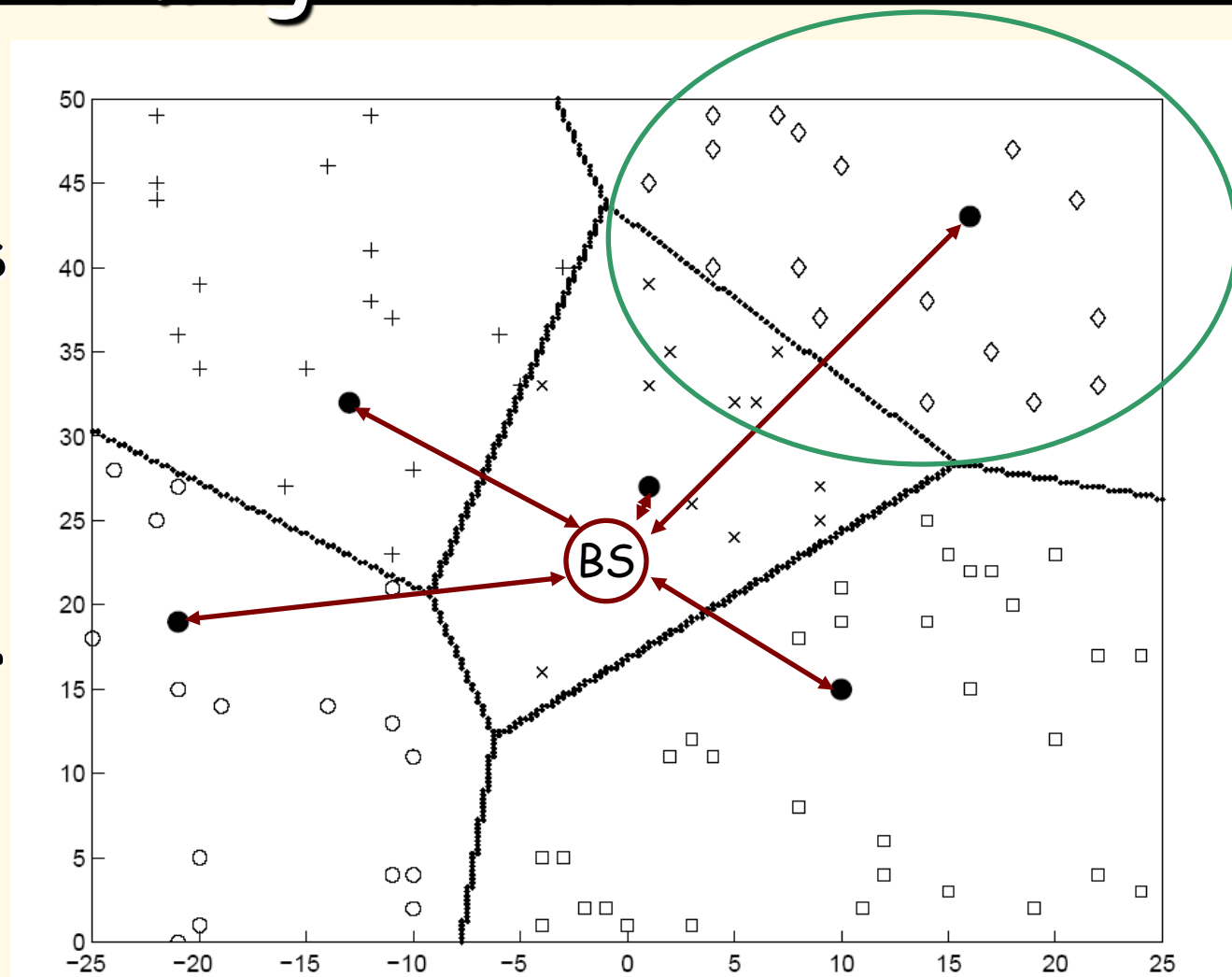

Choosing Cluster Heads/ Forming Clusters

- Periodically select new cluster heads to minimize power consumption and maximize WSN lifetime.
- More complex problem when size of cluster changes dynamically.
- As time goes by, some sensor nodes die!
- Not worried about coverage issues!

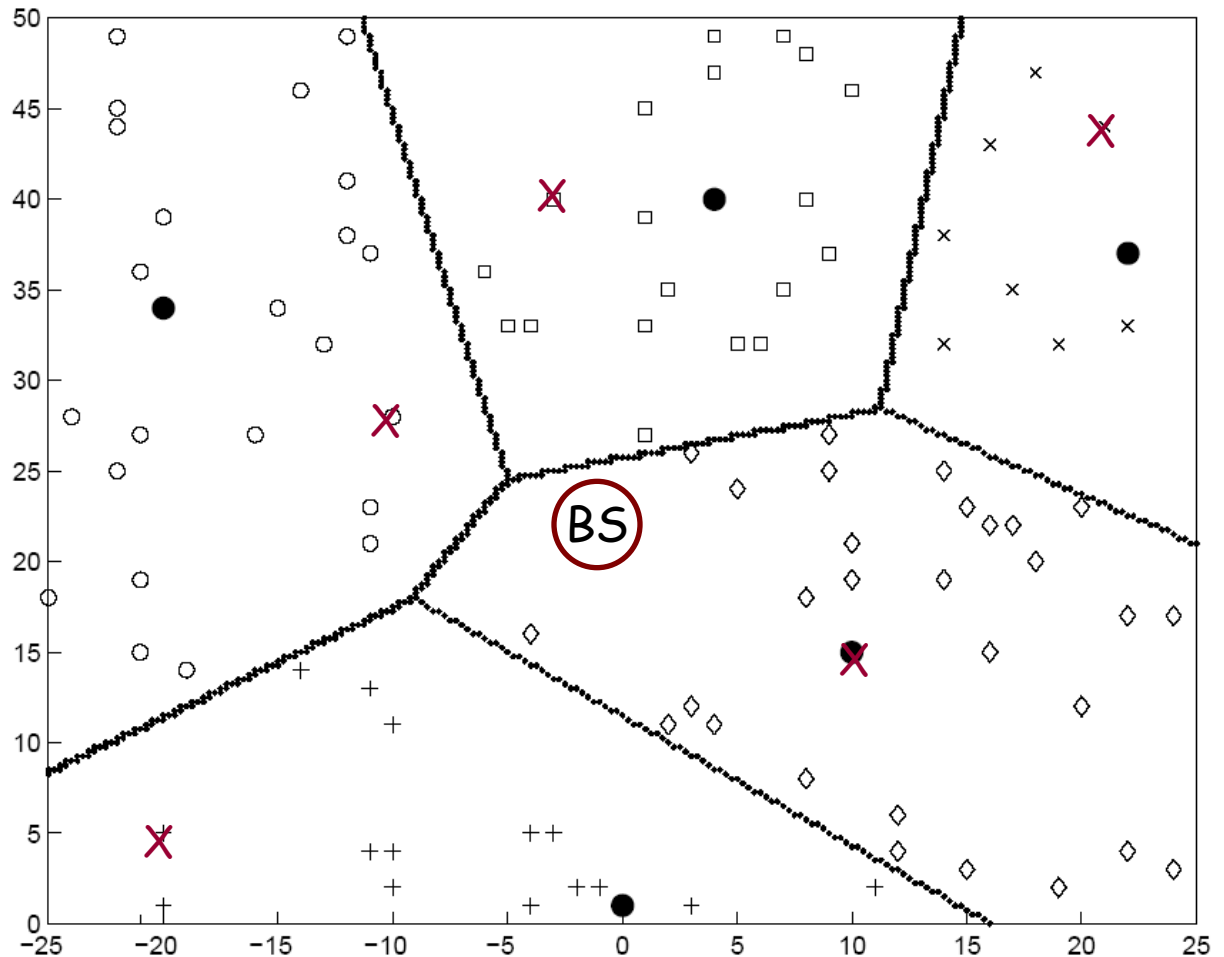

Dynamic Cluster Formation

- TDMA cluster algorithms:
 - LEACH, Bluetooth, ...
- Rick Skowrya's MS thesis:
"Energy Efficient Dynamic Reclustering Strategy for WSNs"
 - 'Leach-like' with a fitness function and periodic re-clustering.
 - He designed a distributed genetic algorithm to speed the re-cluster time.

Power-Aware MAC Protocols



Wireless Sensor Networks

Power Aware MAC Protocols

1997

1998 PAMAS

1999

2000 SMACS

2001 **S-MAC** CSMA/ARC

2002 **LPL** NPSM STEM

2003 DE-MAC EMACs Sift **T-MAC**

2003 TinyOS-MAC

2004 AI-LMAC B-MAC D-MAC DSMAC

2004 L-MAC MS-MAC TA WiseMAC

2005 Bit-MAC FLAMA M-MAC P-MAC

2005 RateEst-MAC SeeSaw Z-MAC

Power Aware MAC Protocols

2006	PSM	SCP-MAC	SS-TDMA	TRAMA
2006	X-MAC			
2007	C-MAC	Crankshaft	MH-MAC	ML-MAC
2007	RMAC	Sea-MAC		
2008	AS-MAC	DS-MAC	DW-MAC	Koala
2008	RI-MAC	W-MAC		
2009	ELE-MAC	MD-MAC	ME-MAC	RA-MAC
2009	Tree-MAC	WUR-MAC		
2010	A-MAC	BuzzBuzz	MiX-MAC	NPM
2010	PE-MAC	VL-MAC		
2011	AdaptAS-MAC	BAS-MAC	Contiki-MAC	EM-MAC
2011	MC-LMAC			

Power Aware MAC Protocols

Three approaches to saving power:

1. **TDMA**: TRAMA, EMACs, L-MAC
2. **Schedule**: PAMAS, S-MAC, T-MAC, D-MAC, PMAC, SCP-MAC, Crankshaft, AS-MAC
3. **Low Power Listening**: LPL, B-MAC, WiseMAC, X-MAC

****Newest approaches include**

4. **Receiver Initiated**: RI-MAC, A-MAC, LPP

Sensor-MAC (S-MAC)

- All nodes periodically listen, sleep and wakeup. Nodes **listen and send** during the active period and **turn off** their radios during the sleep period.
- The beginning of the active period is a SYNC period used to accomplish periodic synchronization and remedy clock drift **{nodes broadcast SYNC frames}**.
- Following the SYNC period, data may be transferred for the remainder of the fixed-length active period using RTS/CTS for unicast transmissions.

Sensor-MAC (S-MAC)

- Long frames are fragmented and transmitted as a burst.
- SMAC controls the duty cycle by trading off energy for delay.
- However, as density of WSN grows, SMAC incurs additional overhead in maintaining neighbors' schedules.

S-MAC

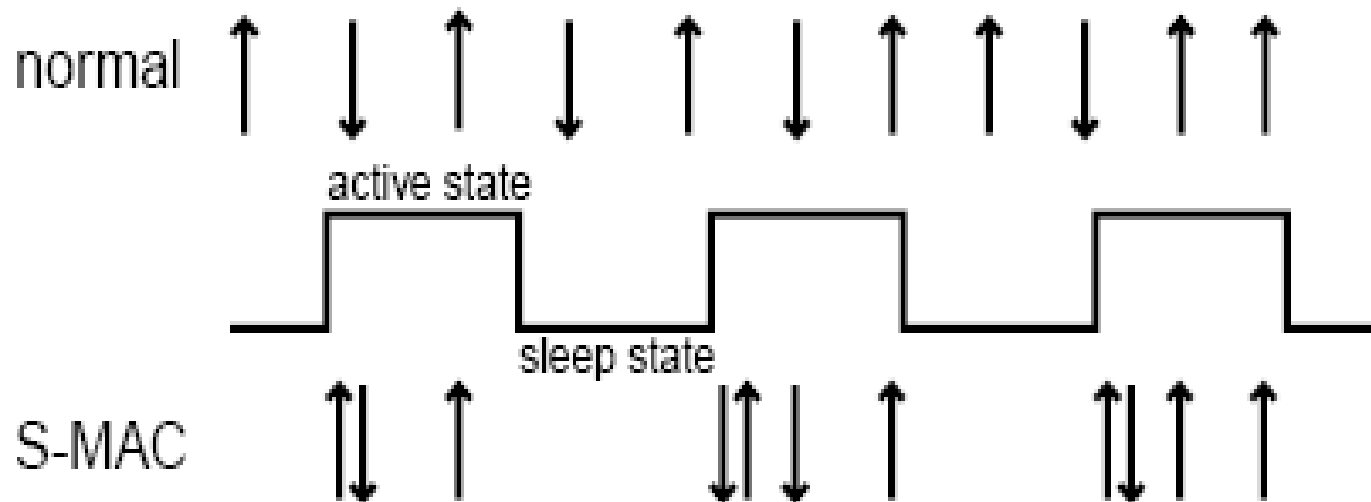

Figure 1: The S-MAC duty cycle; the arrows indicate transmitted and received messages; note that messages come closer together.

Timeout-MAC (T-MAC)

- TMAC employs an **adaptive duty cycle** by using a very short listening window at the beginning of each active period.
- After the SYNC portion of the active period, RTS/CTS is used in a listening window. If no activity occurs within a timeout interval (15 ms), the node goes to sleep.
- TMAC saves power at the cost of reduced throughput and additional delay.

T-MAC

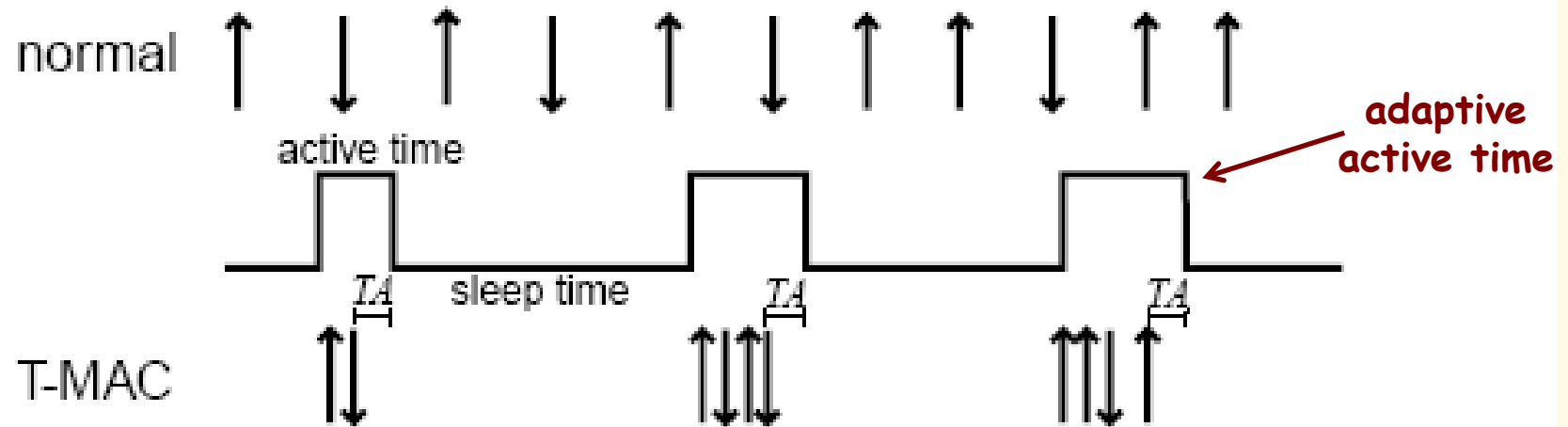
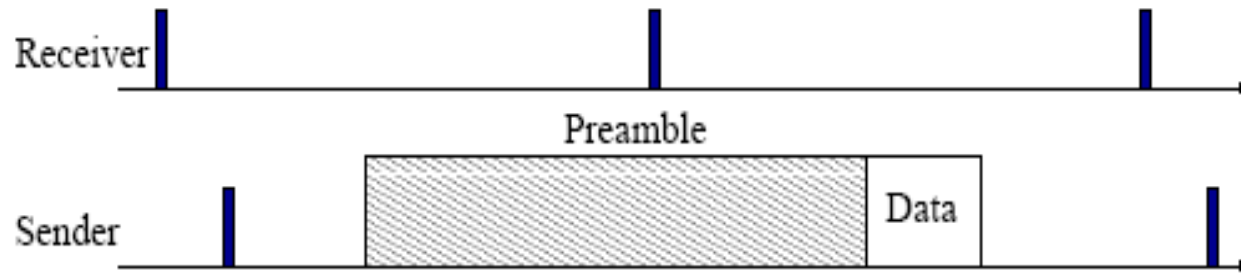
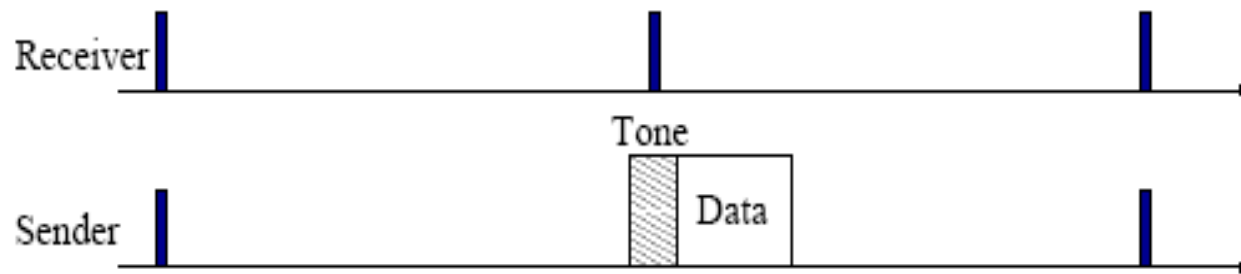

Figure 2: The basic T-MAC protocol scheme, with adaptive active times.

LPL and SCP-MAC



(a) Low-power listening (LPL)



(b) Synchronized channel polling (SCP)

Figure 1. Sender and receiver synchronization schemes.

X-MAC

- X-MAC is an LPL variant that aims to address:
 - Overhearing, excessive preamble and incompatibility with packetizing radios (e.g., CC2420).
- Uses strobed preambles where preambles contain receiver(s) address information.
- Addresses multiple transmissions to one receiver by having subsequent transmitters view the ACK, back-off and then send without any preamble.

X-MAC

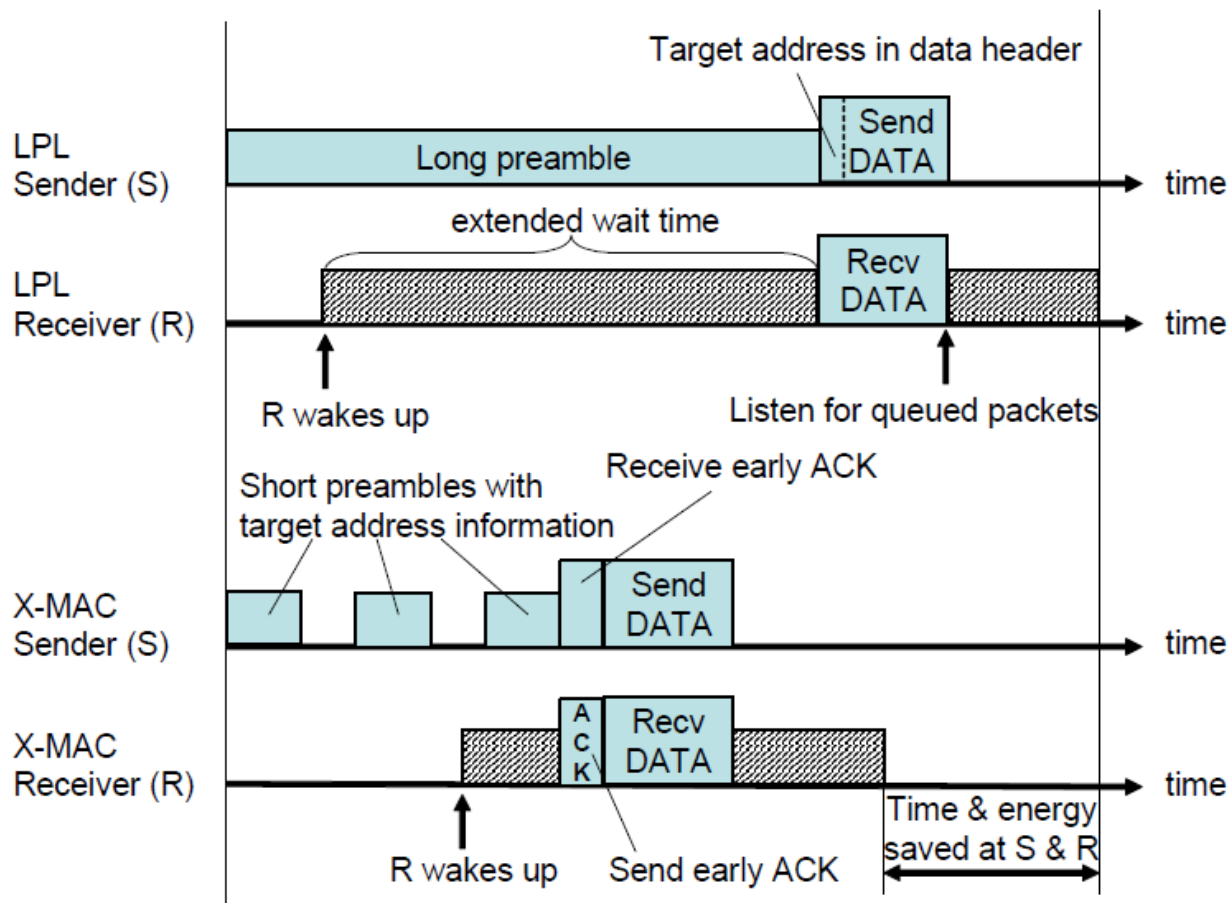

Figure 1. Comparison of the timelines between LPL's extended preamble and X-MAC's short preamble approach.

WSN Outline

- Introduction
- Mote Revolution
- Wireless Sensor Network (WSN) Applications
- WSN Details
- Types of Wireless Sensor Networks (WSNs)
- Tiered Architectures
- Dynamic Cluster Formation
- Power-Aware MAC Protocols
 - S-MAC, T-MAC, LPL, X-MAC
- The Internet of Things

WSN Summary

- Introduction
- Mote Revolution
- Wireless Sensor Network (WSN) Applications
- **WSN Details**
- **Types of Wireless Sensor Networks (WSNs)**
- Tiered Architectures
- Dynamic Cluster Formation
- Power-Aware MAC Protocols
 - **S-MAC, T-MAC, LPL, X-MAC**
- The Internet of Things