

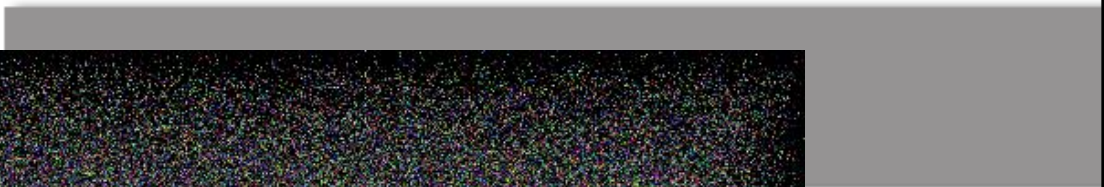

**CS 563 Advanced Topics in
Computer Graphics**
Regular Grids

by Damon Blanchette

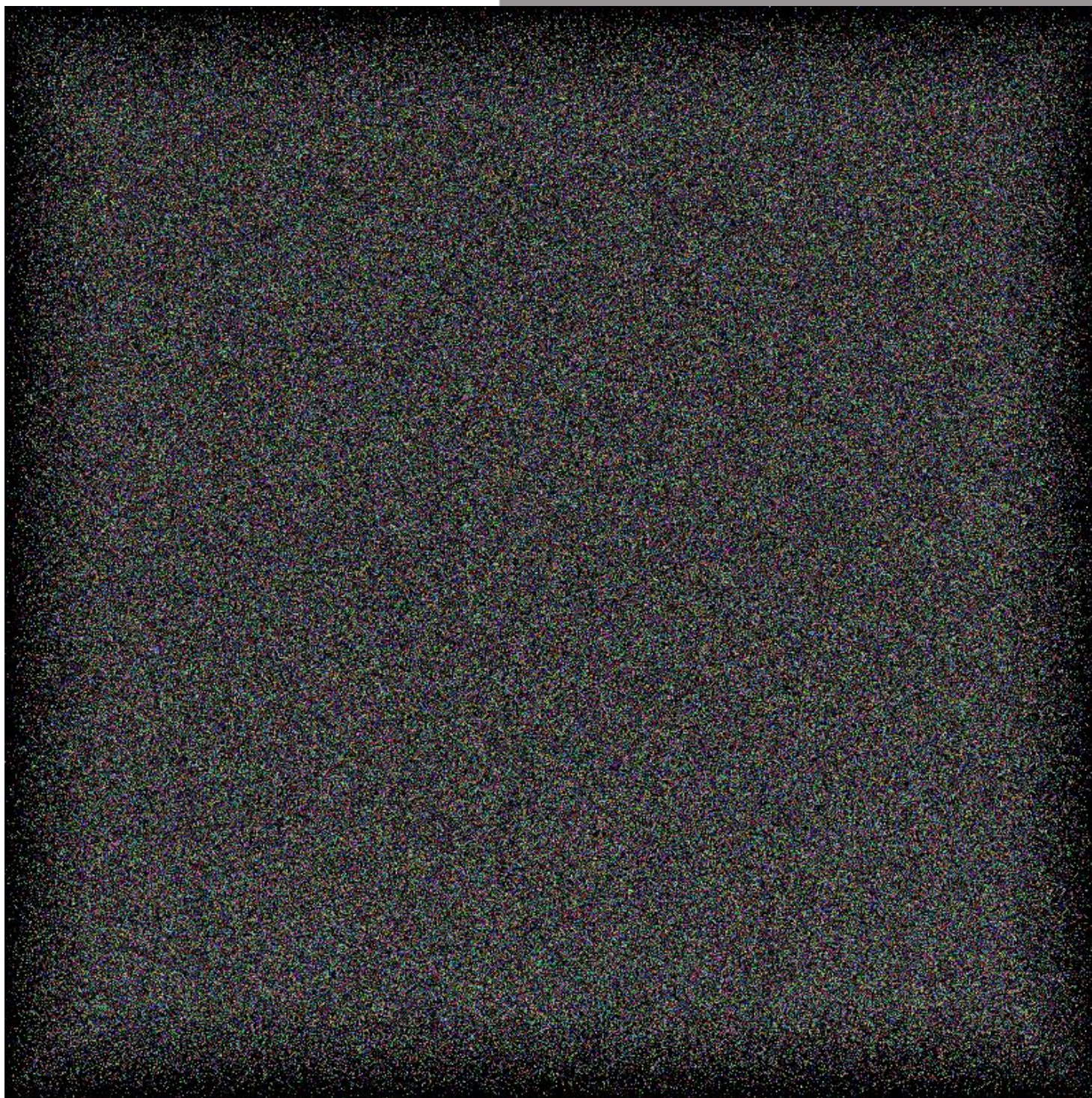

What is a regular grid?

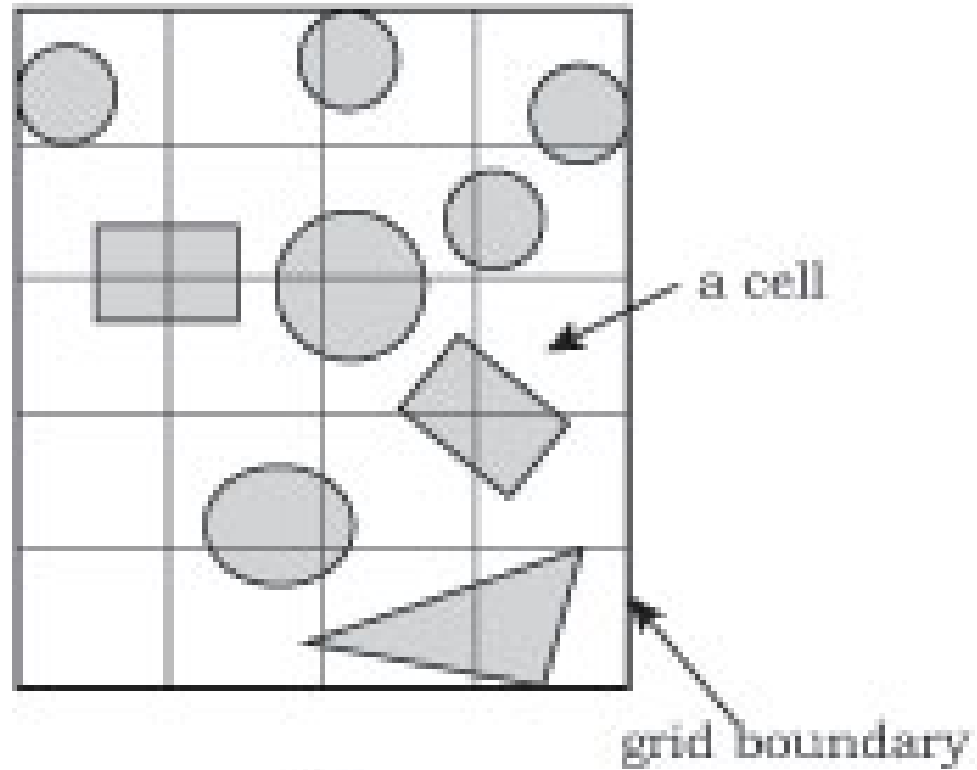

(a)

Grid with a ray

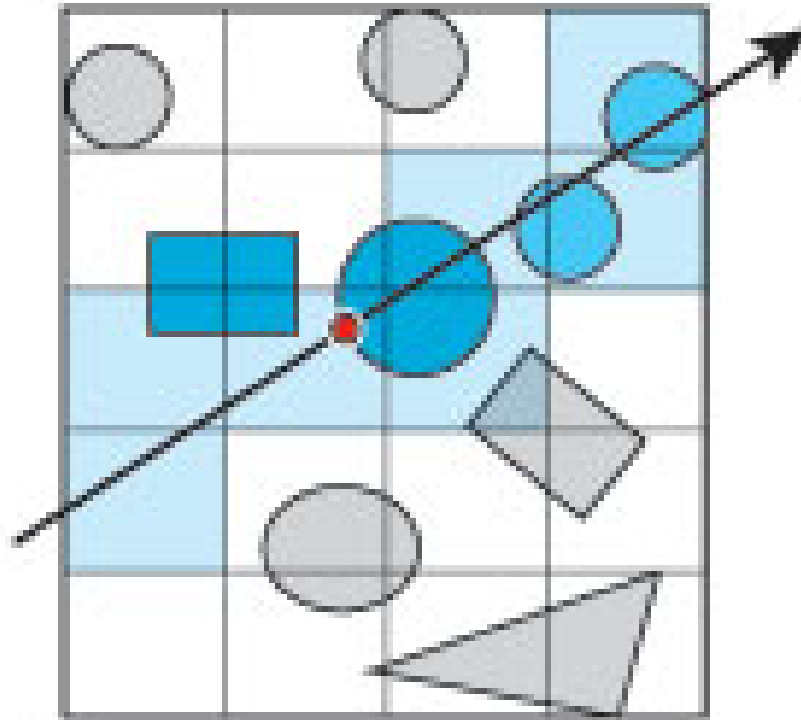

(b)

What kind of savings are we talking about?

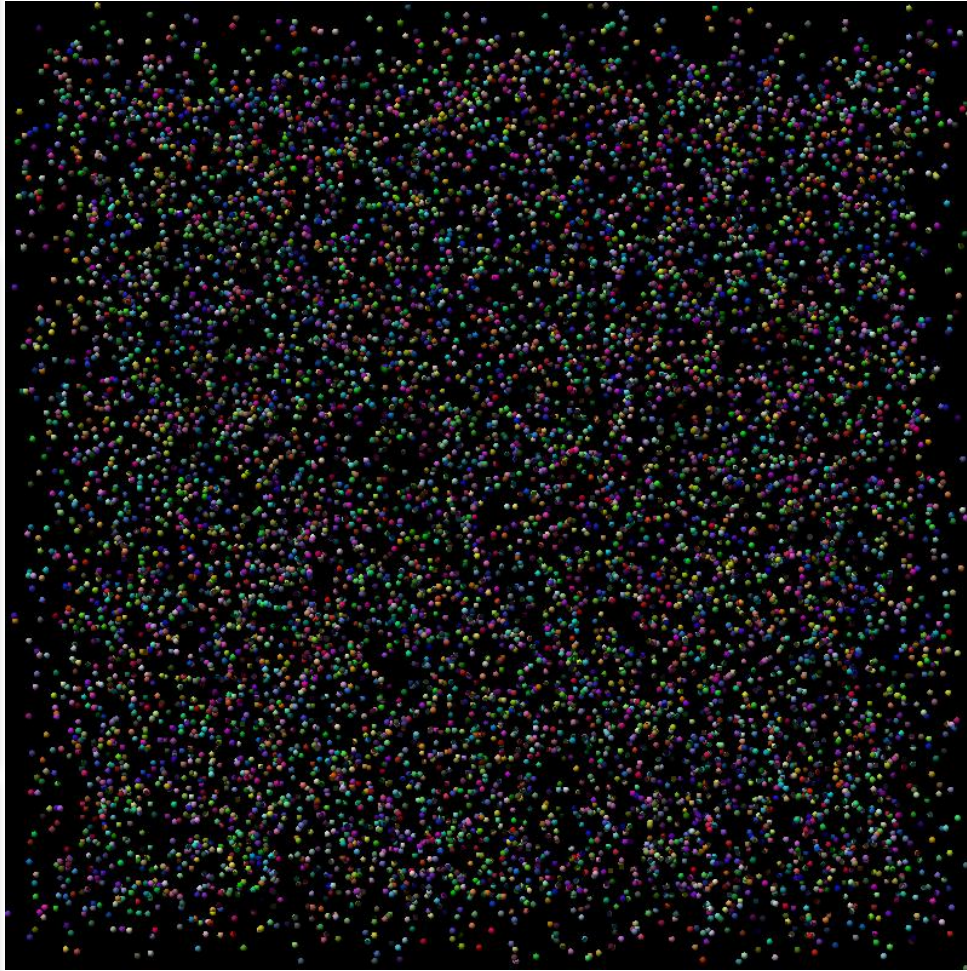

$O(\sqrt[3]{n})$ cells

$O(\sqrt[3]{n})$ objects

Best case: $O(\log n)$
intersections

How do we make a grid?

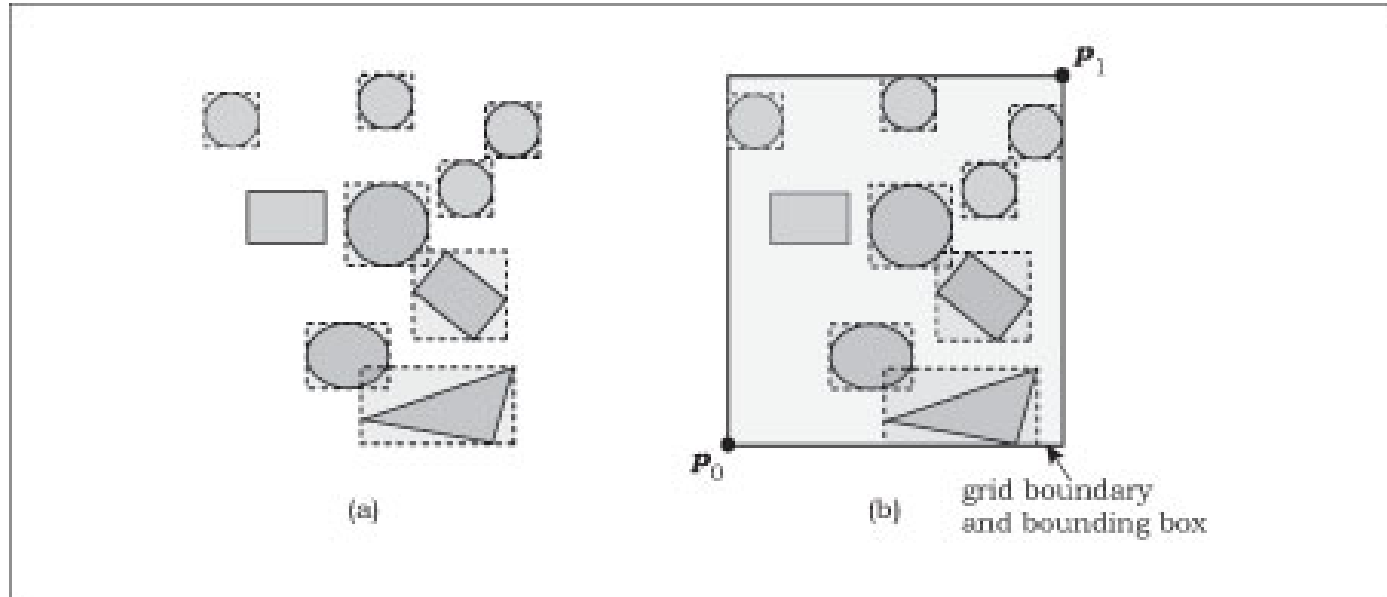

1. Add the objects
2. Compute the bounding box
3. Set up the cells

Part 1: Add the objects

```
Grid* grid_ptr = new Grid;
```

```
grid_ptr->add_object(sphere_ptr);
```

Part 2: Compute the bounding boxes

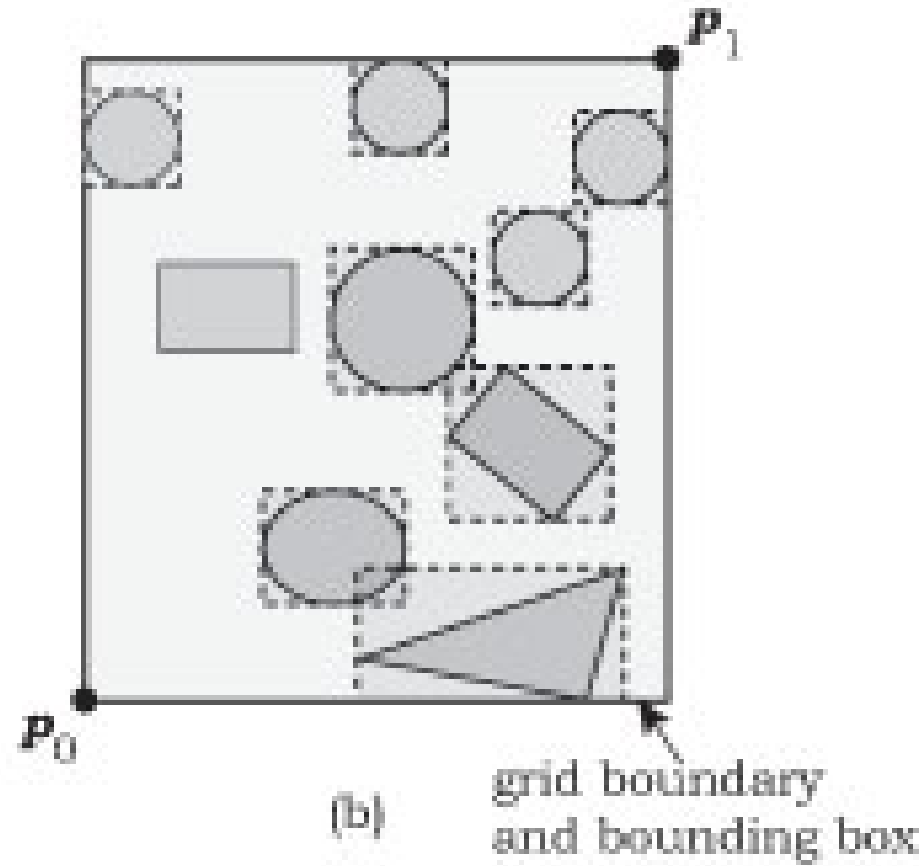

Part 3: Set up the cells

vector<GeometricObject* > cells;

$$s = \left(w_x w_y w_z / n \right)^{1/3}$$

$$n_x = \text{trunc}(mw_x / s) + 1$$

$$n_y = \text{trunc}(mw_y / s) + 1$$

$$n_z = \text{trunc}(mw_z / s) + 1$$

Number of cells will be around $m^3 n$

Indexing: Which Cell is my Home?

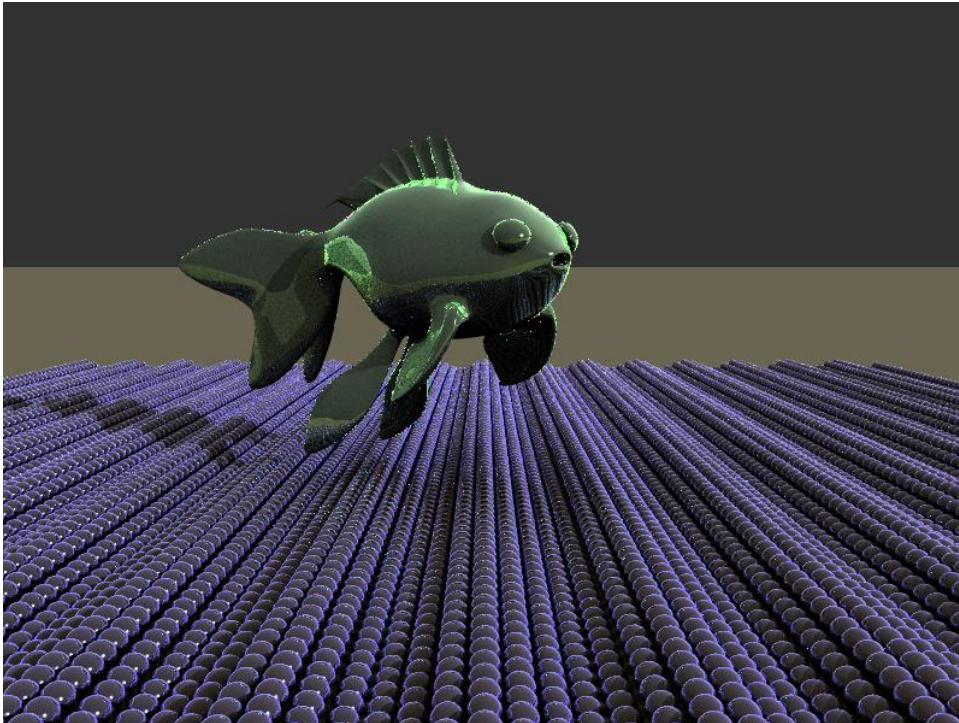

vector<GeometricObject* > cells;

index of the (i_x, i_y, i_z) cell = $i_x + n_x i_y + n_x n_y i_z$

Which Cell is my Home?

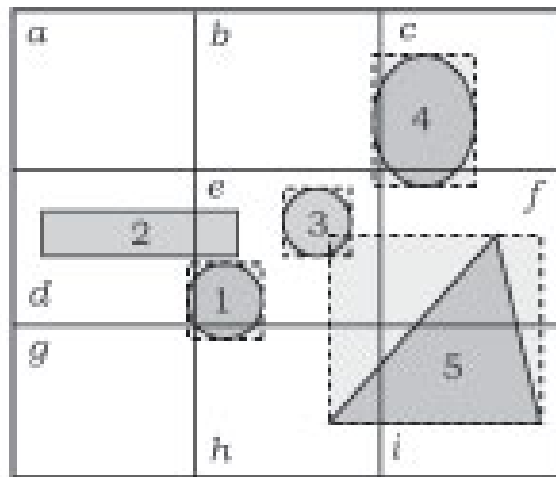

(a)

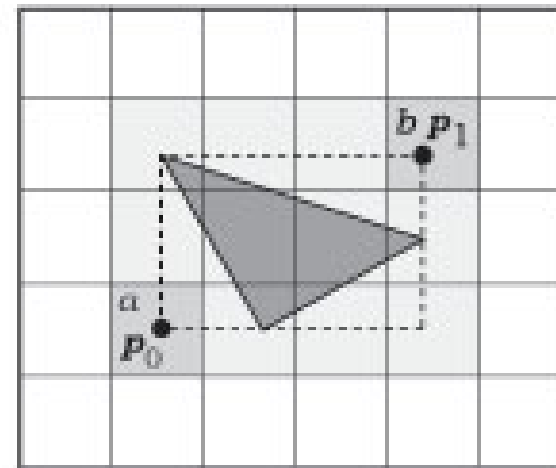

(b)

Which Cell is my Home?

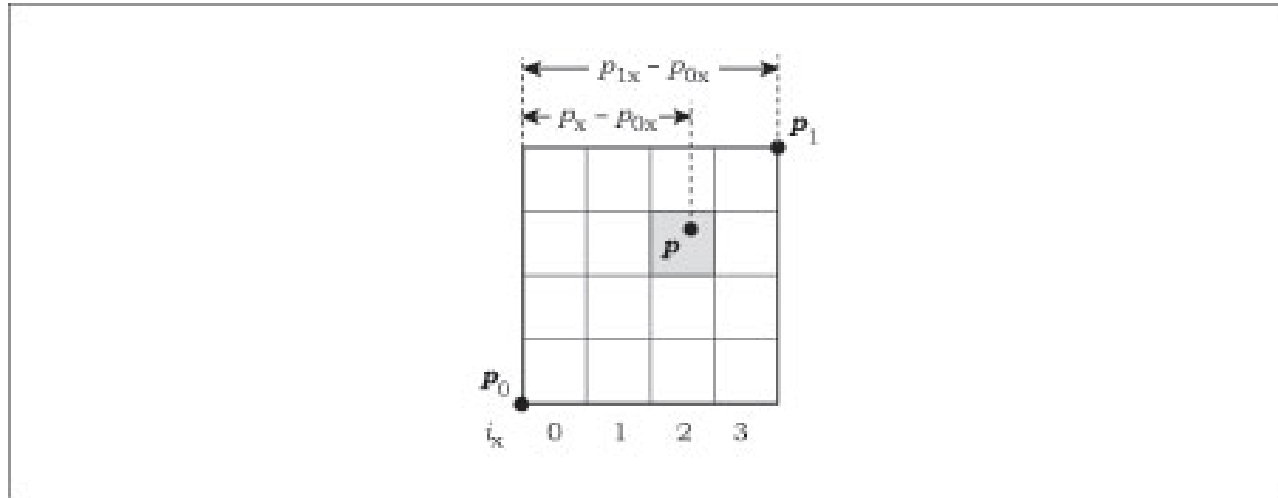

$$f(p_x) = (p_x - p_{0x}) / (p_{1x} - p_{0x}) \in [0.0, 1.0],$$
$$i_x = \lfloor n_x f(p_x) \rfloor \in [0, n_x]$$

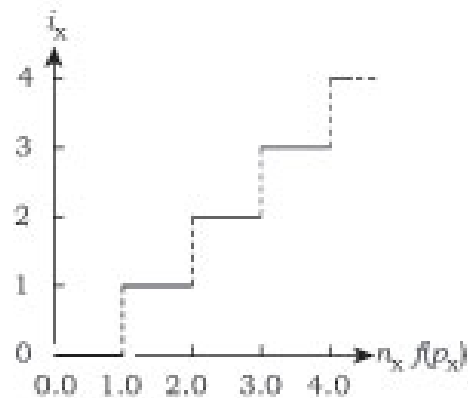

(a)

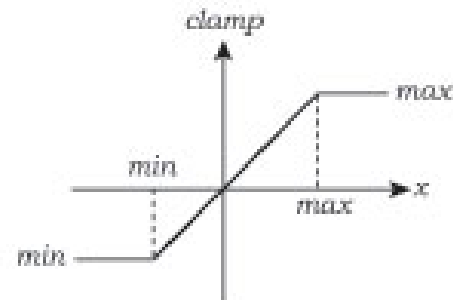

(b)

If the ray misses the grid's bounding box
return false

If the ray starts inside the grid
find the cell that contains the ray origin

Else

find the cell where the ray hits the grid from
the outside

Traverse the grid

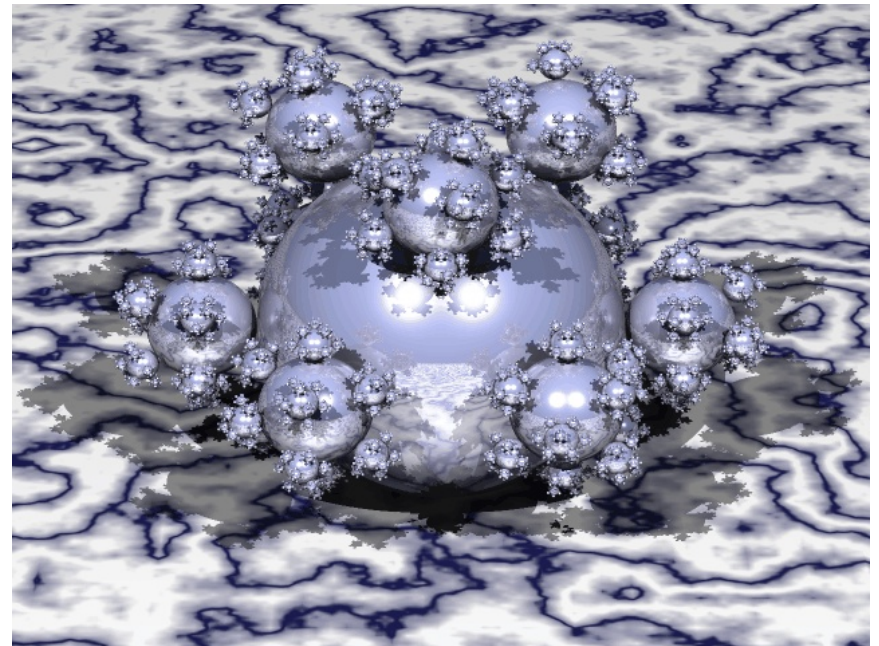

Traversing the Grid

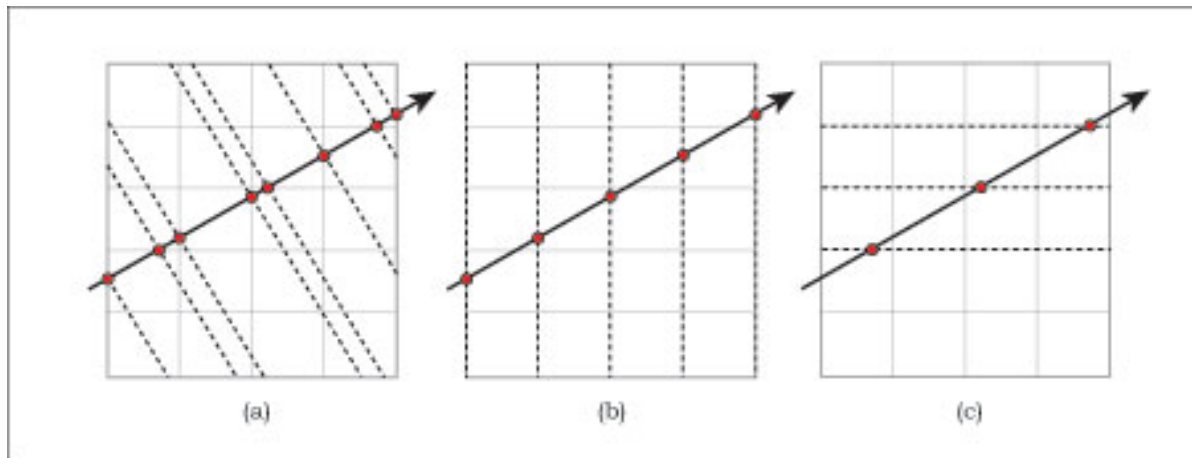
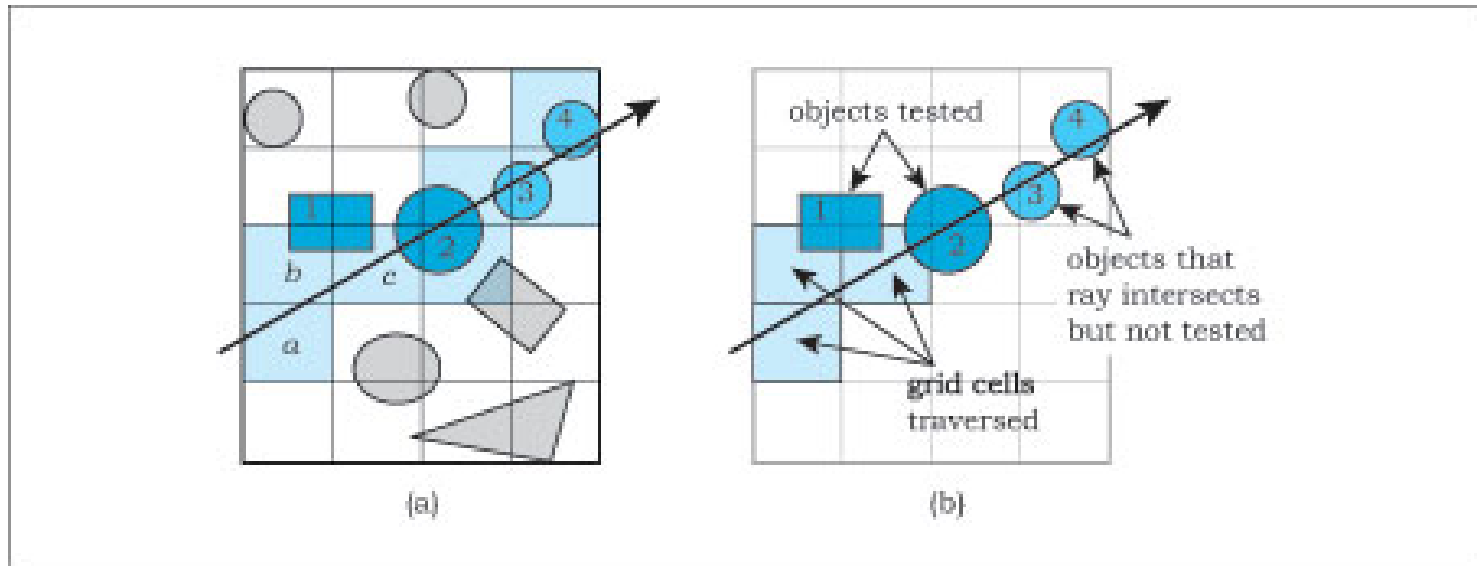

$$dt_x = (t_{x \max} - t_{x \min}) / n_x$$

$$dt_y = (t_{y \max} - t_{y \min}) / n_y$$

$$dt_z = (t_{z \max} - t_{z \min}) / n_z$$

Traversing – Next Cell

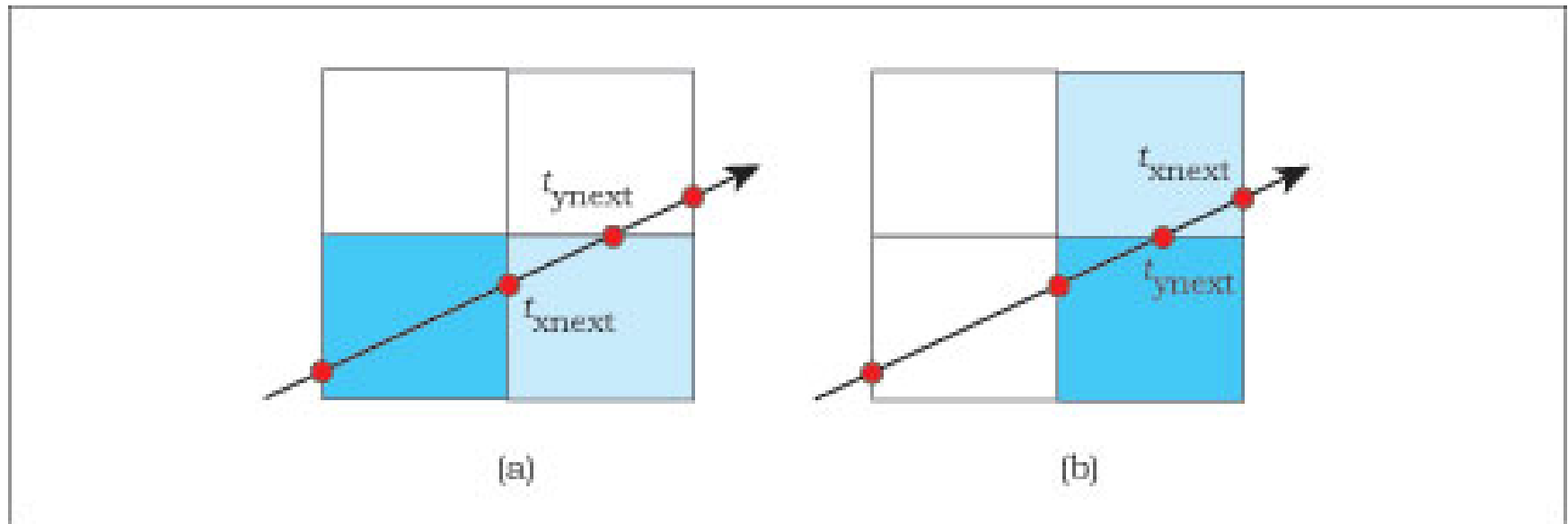

1. Compute t_{xnext} and t_{ynext} for the initial cell
2. Specify a condition to terminate the algorithm
3. Step the ray through the grid

Transformed Objects

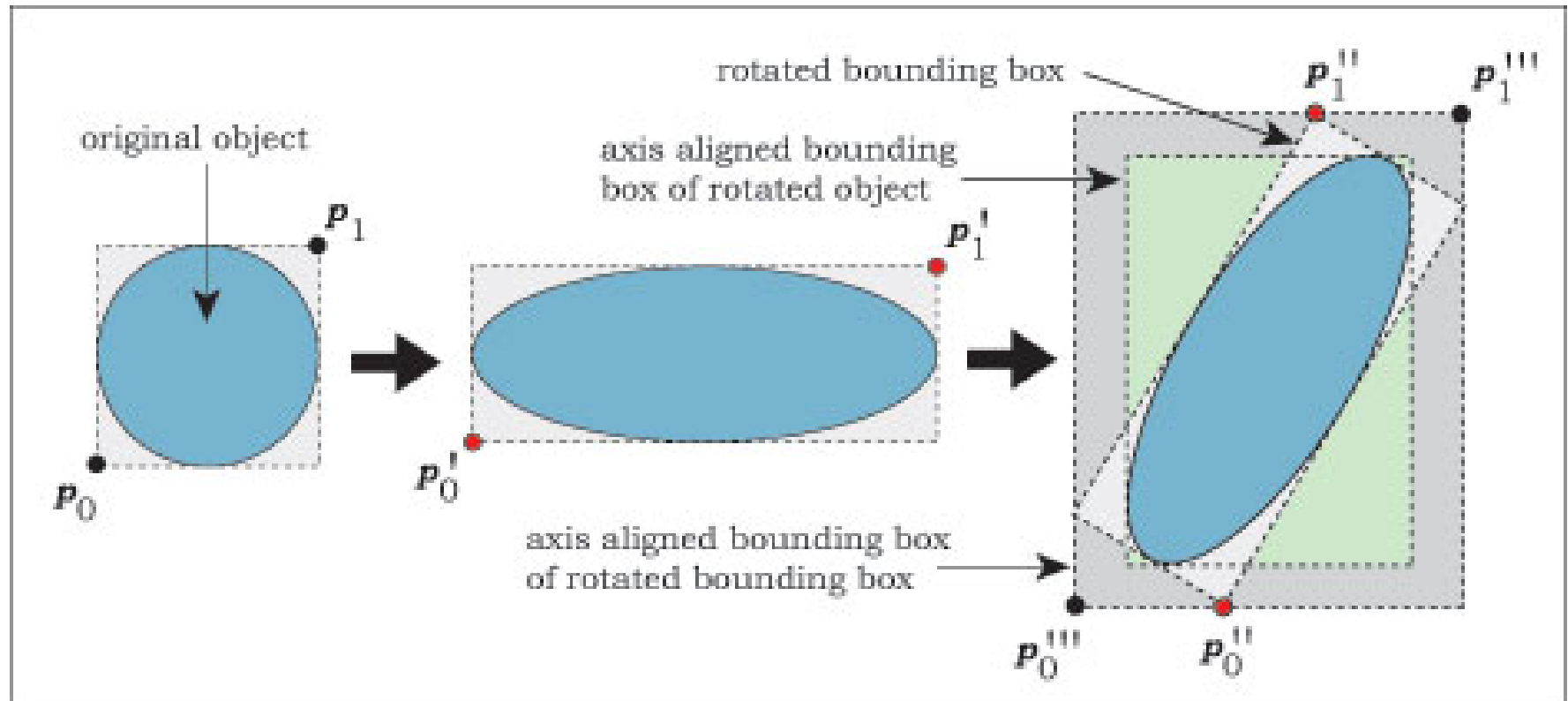

What about a BVH?

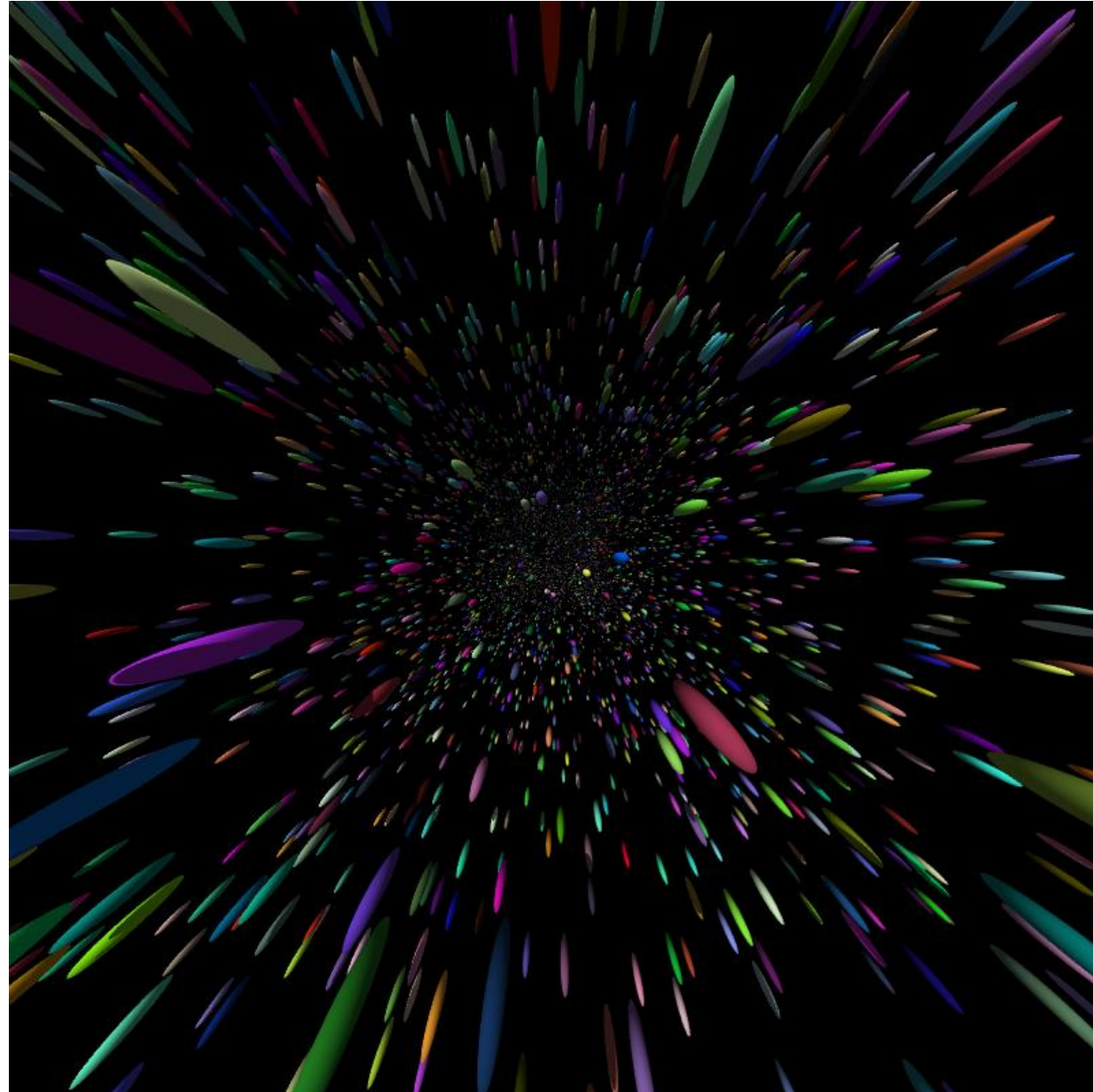

Questions?

?

References

- Suffern, Kevin. *Ray Tracing from the Ground Up*. A.K. Peters, 2007