

Quenching-Understanding, Controlling and Optimizing the Process

Shuhui Ma, Aparna. S. Varde, Makiko Takahashi, Darrell. K. Rondeau,
Md. Maniruzzaman and R. D. Sisson, Jr.

Center for Heat Treating Excellence
Materials Science and Engineering Program, Mechanical Engineering Department
Worcester Polytechnic Institute (WPI), Worcester, MA 01609

Abstract

Each year millions of dollars are lost as a result of distortion, cracking and mechanical property variations due to unexpected problems in the quenching process. A thorough understanding of the variations in quenching fluid's performance as a function of the medium's physical properties, system variables and part geometry is not currently available.

In this paper the results of a series of experiments using four different quench probes in a wide variety of quenching media and process parameters will be presented and discussed. The experimental results are presented in terms of the calculated effective heat transfer coefficients $h(T)$ as a function of metal surface temperature. The data is stored in a new database QuenchPAD[1] that can effectively be used via a Decision Support System called QuenchMiner[1].

QUENCHING, as one of the most important processes of heat treatment, can improve the performance of various metallic alloys greatly, but an important side effect of quenching is the formation of thermal and transformational stresses that cause changes in size and shape that may result in cracks[2]. Therefore, the technical challenge of quenching is to select the quench medium and process that will minimize the various stresses that develop within the part to reduce cracking and distortion while at the same time providing heat transfer rates sufficient to yield the desired as-quenched properties such as hardness [3].

The performance of a quench medium can be characterized by its ability to extract heat from the part surface. It can be expressed in two ways – by measuring hardness of the quenched part as a function of position beneath the surface or by measuring time-temperature data at pre-specified locations in a standard specimen. Most of the commercial

Quench Sensors/Probes measure the time-temperature data, which are later used to estimate quench severity indices, such as, hardening power (HP) [4, 5], Castrol Index (CI) [6, 7], V-Values [6] and Quench Factor (QFA) [8-10]. Those indices can be correlated with the hardness of the quenched part.

The quenching probes have been produced in a great variety of shapes, including cylinders, spheres, square bars, plates, rings and coils, round disks and production parts. Also the probes have been constructed of various materials, including alloy and stainless steels, silver, nickel, copper, gold and aluminum [6].

The heat transfer coefficient is usually used to characterize the quenching abilities of the quenching system. In this paper four different quench probe systems, CHTE probe, IVF probe, Liscic-NANMAC Probe System and CHTE plate probe, are presented. The heat transfer coefficients for these probe systems have been presented. The database QuenchPAD that stores the quenching data and the Decision Support System QuenchMiner are also presented here.

Quench Probe systems

CHTE Quench Probe System. The CHTE Quench Probe System is shown in Figure.1. The system consists of notebook PC based data-acquisition system, pneumatic cylinder with air valve, a small box furnace, 1-L size beaker for quench medium and K-type thermocouple-connecting rod-coupling-interchangeable probe tip assembly. The pneumatic cylinder rod moves the probe down into the quench tank from the box furnace. The pneumatic cylinder is connected to the pneumatic valve by two white tubes as shown.

The dimensions of the probe along with the coupling and the connecting rod are shown in Figure 2. The main feature of this characterization system is the ability of changing the probe tip. The probe tip can be fabricated from

any metallic alloy of interest to be heat treated using quenching process.

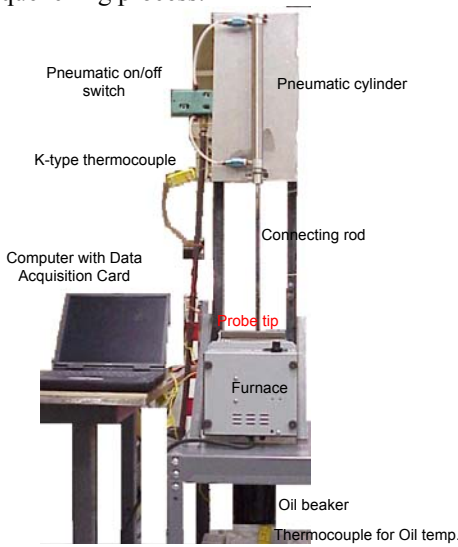

Fig. 1 CHTE Quench Probe System [3, 11]

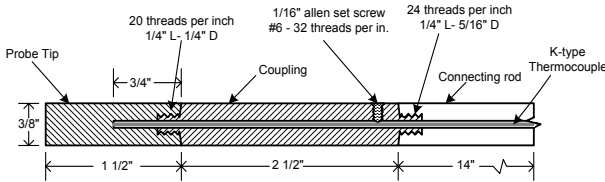

Fig. 2 CHTE probe-coupling-connecting rod assembly [3, 11]

IVF SmartQuench System. IVF SmartQuench System, as shown in Figure 3, is the improved version of IVF portable quenchant tester [12] and is used to characterize liquid quenchants, such as oils and polymer solutions. The system consists of a cylindrical Inconel probe (12.5 mm dia. and 60 mm long) connected with a data acquisition system using a single thermocouple. The quenchant testing system generates the temperature as a

function of time and the cooling rate curves by immersing the heated probe in the liquid quenchant and measuring the data to estimate the IVF hardening power (HP). HP is the rating index for quenching oil proposed by Segerberg. [4, 5] The goal of the indexing is to select the quenchant that is best suited for a particular application. The HP index is calculated using three characteristic points in the cooling rate curve, the transition temperature from film boiling to nucleate boiling, the cooling rate between 500°C and 600°C, and the transition temperature from nucleate boiling and convection. The IVF quenching system that complies with ISO 9950 is now widely used in industry [12].

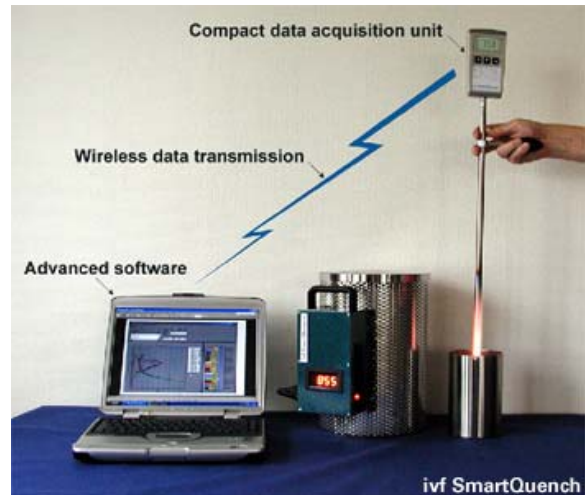

Fig. 3 IVF SmartQuench System [12]

Liscic-NANMAC Probe System. The LISCIC-NANMAC probe [13] [14], as shown in Figure 4, is a cylindrical probe 200 mm long and 50 mm in diameter. The probe is made of AISI304 steel and is instrumented with three thermocouples placed on the same cross-section plane in the middle of the probe's length. One thermocouple is placed at the surface. This thermocouple is

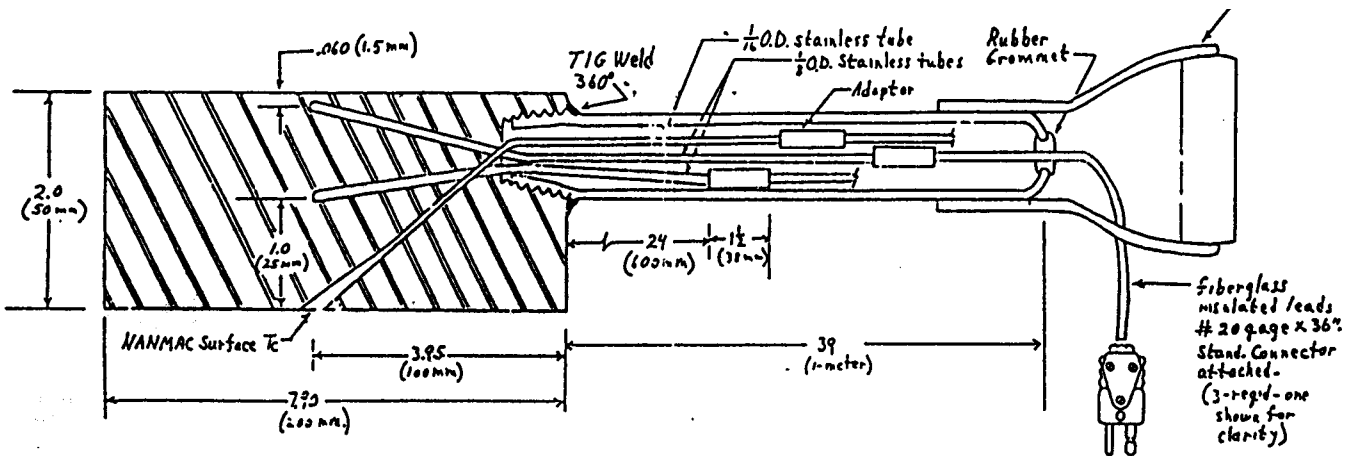

Fig. 4 Schematic of Liscic-NANMAC probe used in TGQAS Temperature Gradient Quenching Analysis System by Liscic [13, 14]

a special type that utilizes a flat ribbon and is known as “self-renewing” thermocouple [15]. The second thermocouple is placed at 1.5 mm below the surface and the third one at the center of the cross-section. This probe is reported to be particularly sensitive for measuring the heat flux during quenching because it accurately measures the temperature gradient from the surface to the center of the probe. The specific feature of this probe is that it measures and records the temperature on the very surface of the probe, with a very fast response time (10^{-5} sec.) and is therefore capable of recording fast changing temperatures.

The software used with the probe (TGQAS) calculates heat transfer coefficients on the probe surface and cooling curves in any arbitrary point of the round bar cross-section of different diameters. TGQAS also predicts microstructure and hardness in any of those points after quenching, for various steel grades that have their Continuous Cooling Transformation (CCT) diagrams are stored in the software.

CHTE Plate Probe System. In order to study the effect of geometry on the heat transfer coefficient during quenching, CHTE plate shaped probe has been designed, as shown in Figure 5. This probe is 200mm long, 30mm wide and 200mm high. Probe material is Inconel 600. This probe is instrumented using four thermocouples as shown in Figure 5. This probe will help us study and understand the heat transfer mechanisms during quenching from a flat vertical surface and the effect of surface orientation on the heat transfer.

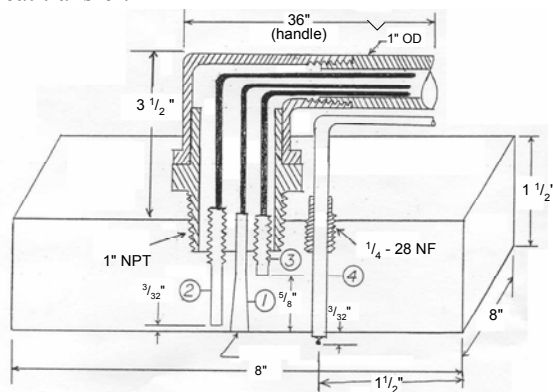

Fig. 5 CHTE Plate Probe Quench System

Results and Discussion

A series of experiments were performed using three different quench probes in the same quenchant: mineral oil T-7-A. The experiments using the fourth probe, CHTE plate probe, are still in progress. The results are discussed as follows:

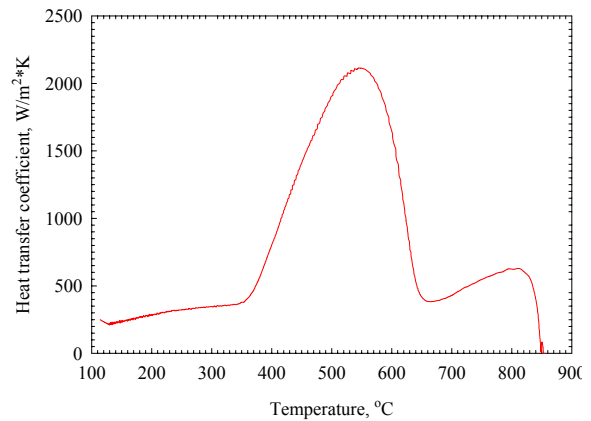

Fig. 6 Heat transfer coefficient for CHTE 304 probe quenched in T-7-A as a function of temperature

CHTE 304 stainless steel probe (3/8" diameter, 1.5" long) was heated to 850°C and then quenched in Houghton T-7-A using the quench probe system shown in Figure 1. The heat transfer coefficient data was calculated using the lumped parameter analysis method and then plotted as a function of the temperature in Figure 6. The heat transfer curve showed the typical cooling regimes for steel in mineral oil: Film boiling, nucleate boiling, natural convection and the transitions in between. Clear Leidenfrost temperature could be seen from the plot at roughly 650°C. The heat transfer coefficient reached a maximum value, 2200W/m²*K, at temperature 550°C.

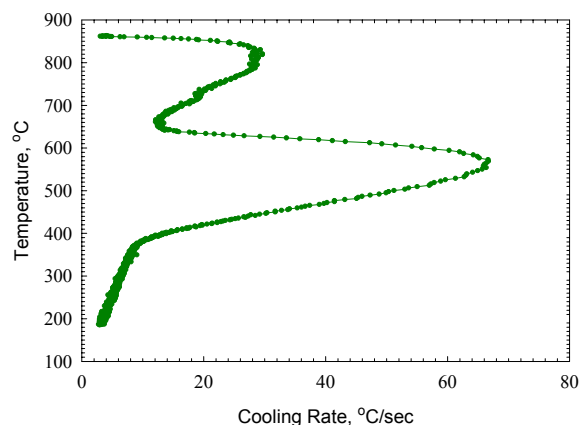

Fig. 7 Cooling rate curve of IVF probe quenched in T-7-A

The same set of experiments was also performed using IVF probe (12.5mm diameter. and 60mm long). IVF probe was usually used to characterize the cooling power of the quenchant. Figure 7 gives the cooling rate curve of IVF probe quenched in T-7-A without agitation. Since the dimension of IVF probe is much bigger than that of CHTE probe, the Biot number is so large that calculation of the heat transfer coefficient can't be performed by lumped parameter analysis. Inverse calculation is needed to calculate the heat transfer coefficient of IVF probe. This work is still underway.

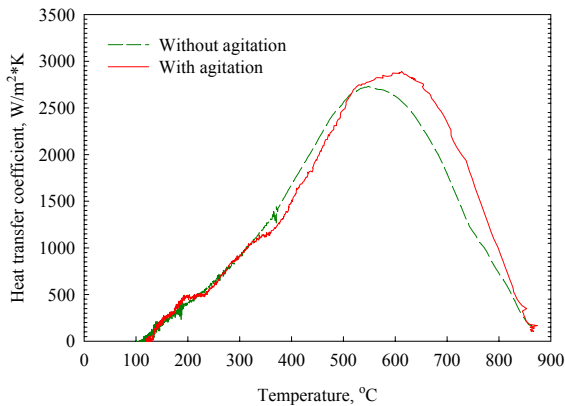

Fig. 8 Heat transfer coefficients of Liscic probe quenched in T-7-A with and without agitation as a function of surface temperature

Heat transfer during quenching is a very complicated process and varies non-linearly with temperature. It can be affected by a variety of parameters, such as the part surface temperature, the surface roughness, the part geometry, the part orientation and the fluid agitation. In order to understand how the fluid agitation affects the heat transfer of the probe, the experiments are performed using the Liscic-NANMAC probe in stagnant and agitated Houghton T-7-A. Figure 8 shows the heat transfer coefficients of Liscic probe quenched in T-7-A with and without agitation as a function of surface temperature. From the figure, it can be seen that the fluid agitation increases the heat transfer during the quenching process and help improve the quenching performance of T-7-A.

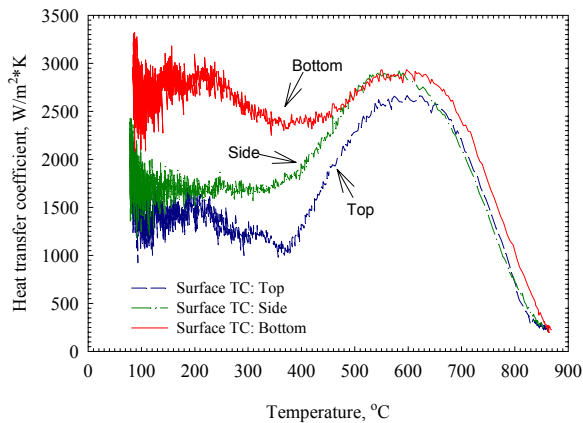

Fig. 9 Heat transfer coefficients of Liscic probe quenched in T-7-A with agitation as a function of surface thermocouple position and surface temperature

The effects of part orientation on heat transfer during quenching have been experimentally investigated. A Liscic-NANMAC quench probe was heated to 850°C and inserted into agitated quench tanks at 45 from vertical. The surface Liscic-NANMAC probe's surface thermocouple's position was varied from the top to the bottom by rotating the probe in 90° increments. The preliminary results indicate that the bottom of the probe cools more rapidly than the top. The

heat transfer coefficients of Liscic probe quenched in T-7-A with agitation as a function of the surface thermocouple position and surface temperature is shown in Figure 9. It can be seen that the agitation doesn't have a significant effect on the partial film boiling and nucleate boiling regions when the probe is inserted into the quench tank at angle 45°, but it does improve the heat transfer at convection stage. Also the heat transfer coefficient for the probe increases as the surface thermocouple turns from the top to the side and then to the bottom due to the enhancing agitation.

QuenchPAD and QuenchMiner

QuenchPAD. The Center for Heat Treating and Excellence (CHTE) at Worcester Polytechnic Institute (WPI) has a Database System called QuenchPAD™, the Quenchant Performance Analysis Database [16] to store mostly textual and numerical data in a relational format. This is a part of the CHTE Quench Probe Characterization System [16]. This Database system manages the quenching information keeping it up-to-date with changes, and running the user's queries.

QuenchPAD™ is built using the commercial package MS Access that serves as a Relational Database Management System [17]. It allows authorized CHTE users to search for experiments and related information based on certain criteria. A sample screen of QuenchPAD is shown in Figure 10. The upper half of this screen allows the user to enter one or more search criteria like Company Name, Probe Material etc. On clicking the search button, details of the concerned quenchant are displayed in tabular form with fields like Experiment, Manufacturer, Quenchant and so on.

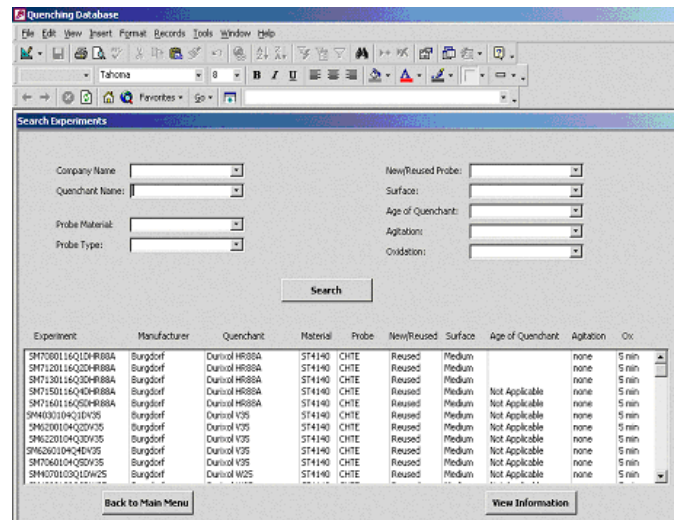

Fig. 10 Sample QuenchPAD™ Screen

However, the users must have the tool MS Access and be familiar with its commands in order to use QuenchPAD™. Also the QuenchPAD™ system must either be made available on the users' local machine or distributed through CD-ROMs, implying more protection and data

management issues. These are some issues of concern regarding QuenchPAD™.

Also, certain types of data such as “the graph showing the cooling rate curve of a particular mineral oil based on the average of some experiments”, or “a statistical table showing the standard deviation for a molten salt quenchant at a given temperature”, may not even have been stored in a Database format. It could be raw data. It is helpful to have a customized repository of integrated information catered to the needs of the users. A Web-based tool called QuenchMiner™, also developed at CHTE, WPI provides this repository. In addition, QuenchMiner also serves as a Decision Support System, enabling users to analyze given cases, based on domain knowledge in Heat Treating, as explained below.

QuenchMiner. QuenchMiner™ [1] is a Web-based Decision Support System (DSS) [18] for querying and analysis of quenching data at CHTE, WPI. QuenchMiner™ makes the existing Database system available on the Web for worldwide access. This allows authorized users to search experimental data over the Web. An example of a QuenchMiner™ search screen is shown in Figure 11.

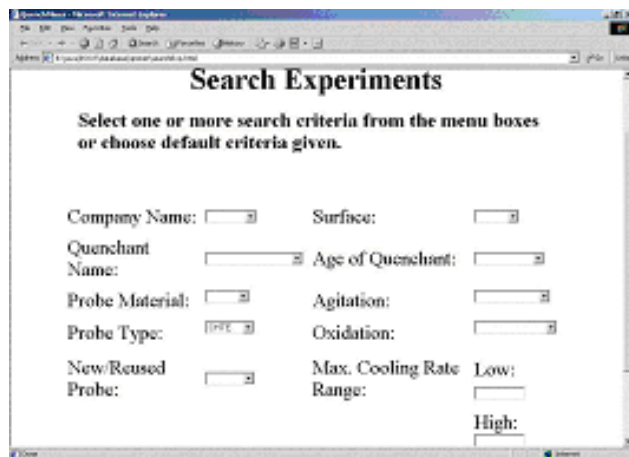

Fig. 11 Search Screen in QuenchMiner™

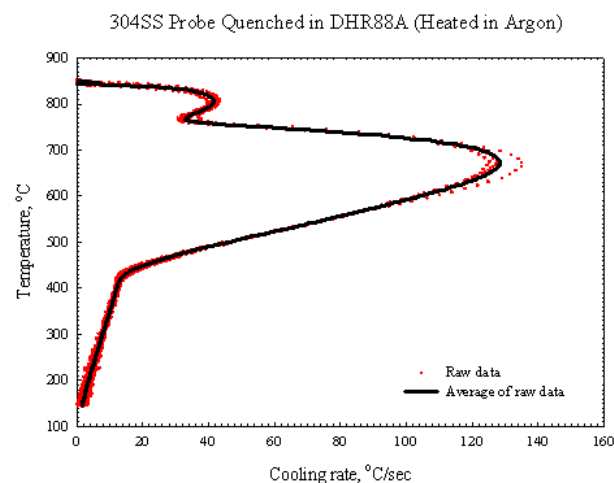

Fig. 12 Cooling Rate Graph of a Quenchant

Results of the search are displayed to the user in tabular form. The user gets “Details” by further navigation from this screen. Details include the graphs plotted during the experiment showing cooling rate curves, heat transfer coefficients and other temperature-time data. QuenchMiner™ aims to store the paths of these graphs and tables directly in the Database in one common server, to enable seamless querying using an Open Source Database like MySQL [19], speeding up and simplifying data retrieval. Figure 12 shows an example of a “Details” screen in QuenchMiner™.

There are certain situations in which the user needs help in making decisions. Users are likely to make decisions and plan for the future based on current performance. QuenchMiner™ provides this decision-making facility. As an example, consider the following scenario. “*Quenching Conditions are provided. Estimate the tendency for distortion in the quenching process.*” The user submits this case for analysis through a form as shown in Figure 13.

Case: Estimate the tendency for distortion in this quenching process.

Details		
QUENCHANT	PART	MFG & STORAGE
Quenchant Type: <u>Water</u>	Part Geometry: <u>Cylinder</u>	Welding: <u>Yes</u>
Viscosity: _____	Size: <u>Thin</u>	Stamping: <u>No</u>
Agitation: <u>Moderate</u>	Oxide Layer: _____	Cold Plastic Deformation: _____
Impellers: _____	Surface: <u>Rough</u>	Fixture: <u>Proper</u>
Speed Improvers: <u>No</u>	Orientation: <u>Vertical</u>	
Temperature: <u>Medium</u>	Carbon Content: <u>Low</u>	
	Grain Nature: <u>Non-uniform</u>	

Fig. 13 DSS User Input

The output of the case after analysis by QuenchMiner™ is shown in Figure 14. The final deduction is that the tendency for distortion in this case is moderate.

F-1 (MAIN::quenching (geometry cylinder) (curvatures t) (cross-section regular) (sharp-corners nil) (part-size thin) (desired-orientation vertical) (quenchant-category water) (slope-graph steep) (agitation moderate) (impellers-used blank)(speed-improvers-used nil) (welding t) (stamping nil) (cold-plastic- deformation blank) (oxide-layer blank) (surface rough) (viscosity low) (quenchant-temp medium) (fixture-type blank) (carbon-content low) (part-orientation vertical) (grain-nature non-uniform) (quenchant-age blank) (polymer-degradation blank))

DIAGNOSIS OF THE GIVEN CASE

The cooling rate in this quenching process is fast

Residual stress during part manufacturing is present

The values of the remaining quenching conditions both given and inferred are displayed as facts above.

On the basis of these quenching conditions it is estimated that the tendency for distortion is moderate

Fig. 14 DSS Output after Analysis

Thus, QuenchMiner™ provides a Web-based System for Quenching Data Analysis and Decision Support. This is an enhancement over QuenchPAD™ that serves as a Database Management System for storage and retrieval of

CHTE Quenching Data. QuenchMiner™ is an exhaustive application of Databases and Expert Systems in the field of Heat Treating, and in particular, Quenching.

Summary

In this paper four different quench probe systems were briefly described and the experimental results are presented in terms of the cooling rate and the calculated effective heat transfer coefficients $h(T)$ as a function of metal surface temperature. The data can be stored in a new database QuenchPAD that can effectively used via a Decision Support System called QuenchMiner.

Acknowledgement

The support of the Center for Heat Treating Excellence (CHTE) and the member companies is gratefully acknowledged.

References

1. Varde, A., et al. *Web-based Data Mining for Quenching Analysis*. in the *13th International Conference on Heat Treating and Surface Engineering (IFHTSE)*. 2002. Columbus, Ohio, USA.
2. Totten, G., E. Howes, and M. A.H, *Steel Heat Treatment Handbook*. 1997, Marcel Dekker, Inc. p. 157.
3. Chaves, J.C., *The Effect of Surface Condition and High Temperature Oxidation on Quenching Performance of 4140 Steel in Mineral Oil*, in *Manufacturing Engineering*. 2001, Worcester Polytechnic Institute: Worcester. p. 8, 9,29.
4. Segerberg, S., *Classification of quench oils: a method of comparison*. *Journal of Heat Treating*, 1988: p. 30-33.
5. Segerberg, S. and J. Bodin. *Investigation of Quenching Conditions and Heat Transfer in the Laboratory and in Industry*. in *International Federation for Heat treatment and Surface Engineering (IFHT)*, *3RD International Seminar on Quenching and Carburising*. 1991. Melbourne, Australia.
6. E.Totten, G., C.E.Bates, and N.A.Clinton, *Handbook of Quenchants and Quenching Technology*. 1993: ASM International. p.62,140-144.
7. L.Canale, et al., *Brazilian quenching oils: Classification of quench severity*.
8. C.E.Bates and G.E.Totten. *Application of quench factor analysis to predict hardness under laboratory and production conditions*. in *The first International Conference on Quenching & Control of Distortion*. 1992. Chicago, Illinois.
9. Totten, G.E., C.E. Bates, and L.M. Jarvis. *Cooling Curve and Quench Factor Characterization of 2024 and 7075 Aluminum Bbar Stock Quenched in Type I Polymer Quenchants*. in *Proceedings of the 16th ASM Heat Treating Society Conference & Exposition*. 1996. Cincinnati, Ohio: ASM International.
10. Staley, J.T., *Quench factor analysis for Aluminum alloys*. *Materials Science and Technology*, 1987. **3**(11): p. 923-935.
11. Maniruzzaman, M. and J.C. Chaves. *CHTE quench probe system - a new quenchant characterization system*. in *International Conference on Frontiers of Design and Manufacturing*. 2002. Dalian, China.
12. IVF, *Quenchotest: Portable test equipment for quenching media*. 2000: IVF (The Swedish Institute of Production Engineering Research):Molndal,Sweden.
13. Smoljan, B. and B. Liscic. *Computer simulation of quenching of steel workpieces with complex shape*. in *Hungarian Scientific Society of Mechanical Engineering, Heat Treatment and Surface Engineering of Light Alloys: Proceedings of the 7th International Seminar of IFHT*. 1999. Budapest, Hungary.
14. Smoljan, B. and B. Liscic. *Simulation & experimental verification of quenching steel workpieces having complex shape*. in *Third International Conference on Quenching and Control of Distortion*. 1999. Prague, Czech Republic: ASM International.
15. Nanigian, J. *Thermocouples:In-Wall, Wall Surface and In-Stream*. in *Heat Treating Proceedings*. 1998: ASM International.
16. Maniruzzaman, M., et al. *CHTE Quench Probe System: A New Quenchant Characterization System*. in the *5th International Conference on Frontiers of Design and Manufacturing (ICFDM)*. 2002. USA.
17. Ramakrishnan, R. and J. Gehrke, *Database Management Systems*. 2000, USA: McGraw Hill Companies.
18. Angehrn, A. and S. Dutta, *Case-Base Decision Support*. *Communications of the ACM*, 1998. **41**(5): p. 157-165.
19. Turner, J., *MySQL and JSP Web Applications*. 2002, Indianapolis, Indiana: SAMS.