



## Who am I?

- Jeff Kesselman, CTO Bluefang Games
  - > 18years in games and multi-media
    - > Rebel Monkey
    - > American Interactive Media (Phillips)
    - > Crystal Dynamics
    - > Total Entertainment Network (TEN)
  - > 9 years at Sun
    - > Win32 Java 1.3 Performance Tuning
    - > Initial leader of the JInput project
    - > 2 yrs in Sun “Game Technologies Group”
    - > 2.5 years at Sun Labs (Project Darkstar)

## Goals For The Week

This week we will cover:

- The History and Structure of Multiplayer games
- The technical game-play challenges going online brings
- Available tools to ease the transition to networked content
- The Challenges of Facebook

Copyright 2008 Sun Microsystems, Inc. All Rights Reserved. Revision A



## What this lecture is about

The Evolutionary History of the Architecture of  
Online Massively Multi-player games

Copyright 2008 Sun Microsystems, Inc. All Rights Reserved. Revision A

## Lecture Overview, Day One

- Day One, Lecture
  - > Evolution of Games
  - > Review: Single-player game structure
  - > Multi-player game structure
  - > MUDs and MMOs

Copyright 2008 Sun Microsystems, Inc. All Rights Reserved. Revision A

## Where game architecture comes from

- Game software has DNA
  - > It carries the history of the industry within it
  - > In order to understand current games, you need to understand the history

Copyright 2008 Sun Microsystems, Inc. All Rights Reserved. Revision A

## Where game architecture comes from

- Game software has DNA
  - > It carries the history of the industry within it
  - > In order to understand current games, you need to understand the history
- Game software usually evolves incrementally
  - > Game development is generally risk adverse
  - > Game development is on tight schedules
  - > Games general vary only in minor way from what came before

Copyright 2008 Sun Microsystems, Inc. All Rights Reserved. Revision A

## Where game architecture comes from

- Game software has DNA
  - > It carries the history of the industry within it
  - > In order to understand current games, you need to understand the history
- Game software usually evolves incrementally
  - > Game development is generally risk adverse
  - > Game development is on tight schedules
  - > Games general vary only in minor way from what came before
- Leaps happen rarely but occasionally
  - > Usually by 'cross-breeding' unrelated software

Copyright 2008 Sun Microsystems, Inc. All Rights Reserved. Revision A

## Single Player Game Architecture

The Game Loop, A review

Copyright 2008 Sun Microsystems, Inc. All Rights Reserved. Revision A

## Start at the beginning

- The primordial ooze of games
  - > BASIC “guess the number”

```

10 N = INT(RND(1)*100 + 1)
20 PRINT "Guess a number between 1 and 100"
30 INPUT G
40 IF G = N GOTO 100
50 IF G < N GOTO 80
60 PRINT "Too high"
70 GOTO 20
80 PRINT "Too low"
90 GOTO 20
100 PRINT "You got it!"
110 END

```

Copyright 2008 Sun Microsystems, Inc. All Rights Reserved. Revision A

## Contains all the “organs” of a modern game

- “The Game Loop”

- > Initialization

```

10 N = INT(RND(1)*100 + 1)

```

- > Update/Render loop

```

20 PRINT "Guess a number between 1 and 100"
30 INPUT G
40 IF G = N GOTO 100
50 IF G < N GOTO 80
60 PRINT "Too high"
70 GOTO 20
80 PRINT "Too low"
90 GOTO 20
100 PRINT "You got it!"

```

- > Intermingled because simple BASIC isn't structured

Copyright 2008 Sun Microsystems, Inc. All Rights Reserved. Revision A

## All games have a game loop

- Turn Based
  - > Stop in Update to collect all input
- Example:
  - > Chess:
    - > Update:
      - input chess move
      - Run Artificial Intelligence (AI) to calculate response
    - > Render:
      - Re-draw or animate chess board

Copyright 2008 Sun Microsystems, Inc. All Rights Reserved. Revision A

## All games have a game loop

- Real Time
  - > Poll inputs in Update and go on
- Example:
  - > First Person Shooter (FPS)
    - > Update:
      - Every N frames (or time ticks)
        - Read input keys
        - Calculate player fire if any
        - Run AI to calculate response
        - Calculate Mobile Object (MOB) fire if any
        - Move Player
        - Move MOBs
    - > Render:
      - Animate 1 frame (or N ticks) of gunfire and motion

Copyright 2008 Sun Microsystems, Inc. All Rights Reserved. Revision A

## Differences Btw Turn based and Real time

- Turn based
  - > Blocking input
  - > One trip around the loop == 1 game turn
- Real Time
  - > Polled input
  - > One trip around the loop == fraction of game turn
- “Game Turn” above is defined as one read of the controllers and the calculation and animation of the response.

Copyright 2008 Sun Microsystems, Inc. All Rights Reserved. Revision A

## Multi-player games

An evolutionary line

Copyright 2008 Sun Microsystems, Inc. All Rights Reserved. Revision A

## Multi-Player, the next evolution

- Multiple Players on one computer
- Turn Based
  - > Players each enter their own move sequentially in Update
- Real Time
  - > Each player has their own set of keys or input device
  - > All players are polled in Update

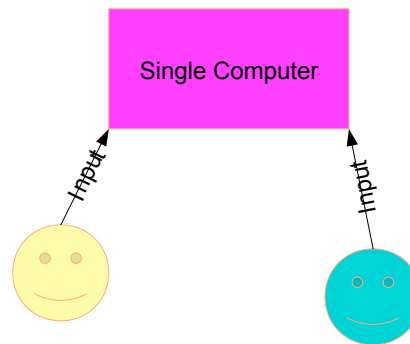

Copyright 2008 Sun Microsystems, Inc. All Rights Reserved. Revision A

## Multi-Station, the first networked games

- Played on LANs
- Non-local players are on virtual devices
  - > Other players input happens on foreign machines
  - > Is communicated over network
  - > Is processed in Update at every machine as if all input was local

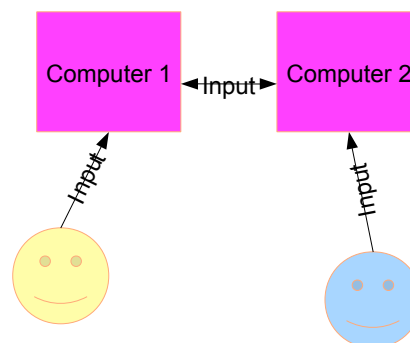

Copyright 2008 Sun Microsystems, Inc. All Rights Reserved. Revision A

## Multi-Station, the first networked games

- The “lock-step” model
  - > Every station is running the same game/simulation (sim)
  - > Works because on a LAN, latency is infinitesimal

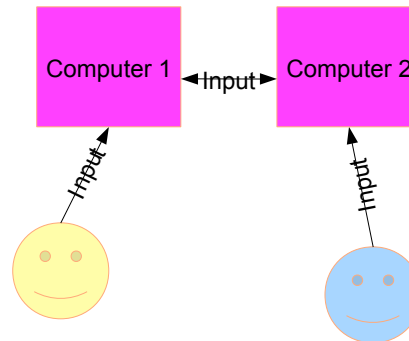

Copyright 2008 Sun Microsystems, Inc. All Rights Reserved. Revision A

## Flight Sims: Open Loop/Asynchronous (Asynch)

- Based on work for SimNet (DIS)
  - > Each system has its own variant world state
  - > Each vehicle is simulated on one machine
    - > Periodic time-stamped state updates sent to others
    - > Lower freq then controller input

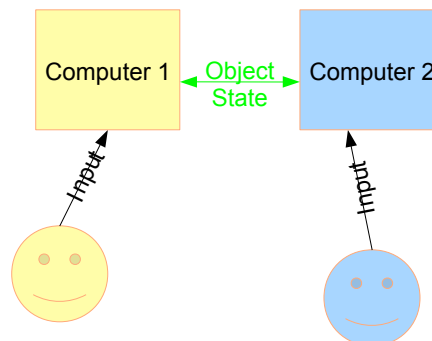

Copyright 2008 Sun Microsystems, Inc. All Rights Reserved. Revision A

## Flight Sims: Open Loop/Asynch

- Dead Reckoning
  - > Each sim makes “best guess” at non-local positions
    - Use vehicle model to assist
      - “Tanks don’t fly”
  - > Corrects as updates are received
    - > Note: Updates always in past.
  - > Requires conflict resolution mechanism
    - > “shooter decides”

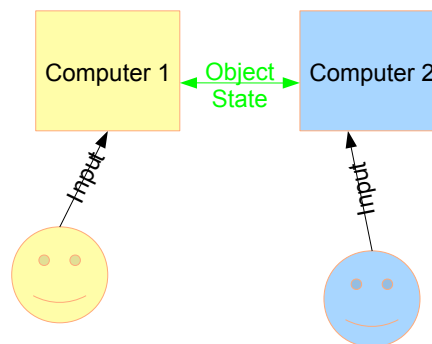

Copyright 2008 Sun Microsystems, Inc. All Rights Reserved. Revision A

## Stepping into Cyberspace

- First Internet capable games/techniques
- Kali
  - > NBIOS emulator over TCP/IP
  - > Lock step games tended to play badly
    - > Reducing packets per second helped
    - > Latency buffering helped
  - > Open loop/asynch tended to play well
    - > Already designed for limited bandwidth and real net latencies
- TCP/IP support added to games
  - > Pluggable 'net drivers'
  - > More attention paid to latency and bandwidth issues

Copyright 2008 Sun Microsystems, Inc. All Rights Reserved. Revision A

## Internet Play: Lock Step Pros and Cons

- Pros ?

Copyright 2008 Sun Microsystems, Inc. All Rights Reserved. Revision A

## Internet Play: Lock Step Pros and Cons

- Pros
  - > Cheat proof
  - > Exact synchronization assured
- Cons ?

Copyright 2008 Sun Microsystems, Inc. All Rights Reserved. Revision A

## Internet Play: Lock Step Pros and Cons

- Pros
  - > Cheat proof
  - > Exact synchronization assured
- Cons
  - > Every player's experience limited by worst case
  - > Handles latency spikes poorly
  - > Handles dropped players poorly
    - > Needs to wait for timeout to determine drop v. spike

Copyright 2008 Sun Microsystems, Inc. All Rights Reserved. Revision A

## Internet Play: Open Loop/Asynch Pros and Cons

- Pros ?

Copyright 2008 Sun Microsystems, Inc. All Rights Reserved. Revision A

## Internet Play: Open Loop/Asynch Pros and Cons

- Pros
  - > Good at hiding latency
    - > Smooth predict/correct over many frames
  - > Better bandwidth control
    - > Can communicate less often
      - 'shape' by distance
      - Out of sight, out of mind
- Cons ?

Copyright 2008 Sun Microsystems, Inc. All Rights Reserved. Revision A

## Internet Play: Open Loop/Asynch Pros and Cons

- Pros
  - > Good at hiding latency
    - > Smooth predict/correct over many frames
  - > Better bandwidth control
    - > Can communicate less often
      - 'shape' by distance
      - Out of sight, out of mind
- Cons
  - > Prone to cheating
    - > Need to trust sender as to position
    - > Need to trust shooter as to hit/miss
  - > Occasional 'warping' or other artifacts
- In general, technique used by all vehicle sims

Copyright 2008 Sun Microsystems, Inc. All Rights Reserved. Revision A

## Quake: The first client/server game

- Server runs authoritative simulation
- Clients run open loop/asynch views
  - > Really rich “controllers” for server.

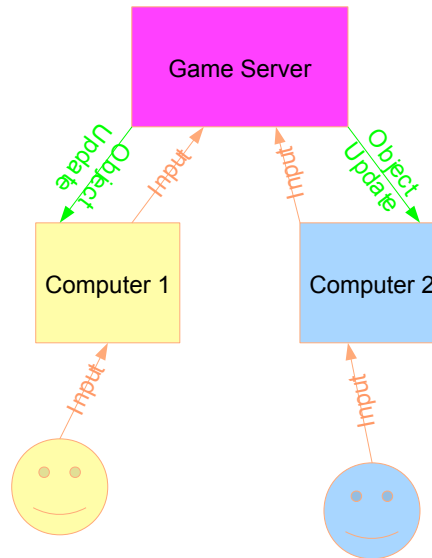

Copyright 2008 Sun Microsystems, Inc. All Rights Reserved. Revision A

## Quake: The first client/server game

- Pros ?

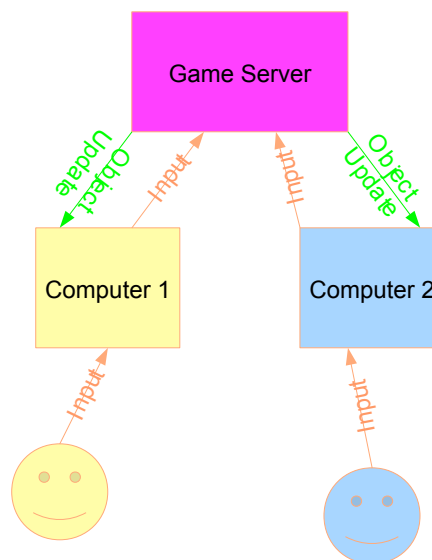

Copyright 2008 Sun Microsystems, Inc. All Rights Reserved. Revision A

## Quake: The first client/server game

- Pros
  - > Cheating is much more difficult
  - > Still not totally impossible
    - > Aimbot
- Cons ?

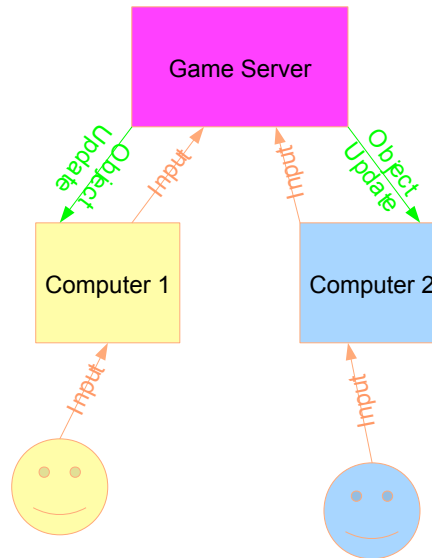

Copyright 2008 Sun Microsystems, Inc. All Rights Reserved. Revision A

## Quake: The first client/server game

- Pros
  - > Cheating is much more difficult
  - > Still not totally impossible
    - > Aimbot
- Cons
  - > What looks like hit to shooter can miss
  - > “Low Ping Bastard” (LPB) effect

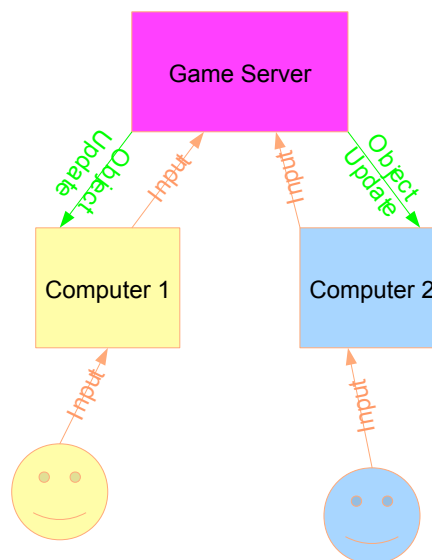

Copyright 2008 Sun Microsystems, Inc. All Rights Reserved. Revision A

## First Person Shooters Today

- Still fundamentally Quake model
- Player interactivity limited to control LPB effect
- Packet encryption to defeat aimbot
  - > Not perfect security, but generally good enough

Copyright 2008 Sun Microsystems, Inc. All Rights Reserved. Revision A

## Game Discovery: LANs

- On LAN, players communicated with broadcast
  - > First, broadcast play
    - > Only one game session per LAN
  - > Later, broadcast discovery, unicast play
    - > Multiple sessions per LAN

Copyright 2008 Sun Microsystems, Inc. All Rights Reserved. Revision A

## Game Discover: WANs

- In Cyberspace, no one can hear you broadcast
  - > On Internet, players need each others IPs
  - > Initially, player entered manually
    - > Found each other through IRC
  - > GameSpy offers discovery service
    - > Programmatic, but still over IRC
    - > Simple directory server plus chat
    - > Funded by advertising on client
  - > TEN and MPath offer complete services
    - > Net APIs and star architecture comm servers

Copyright 2008 Sun Microsystems, Inc. All Rights Reserved. Revision A

## Game Discovery Today

- TEN and MPath are gone
- Gamespy
  - > Industry standard
  - > has expanded data services
  - > Now has comm API
    - > Thin wrapper over peer to peer TCP/IP and UDP
    - > Does UDP socket introduction through IRC
  - > Licensed per game, advertising in Gamespy client
    - > Most games don't use the Gamespy client
- Xbox Live/ PC Live
  - > Microsoft's attempt to get into the TEN/MPath space
  - > Yearly fee, electronic retailing

Copyright 2008 Sun Microsystems, Inc. All Rights Reserved. Revision A

**Tomorrow... MUDs and MMOs or..**

**“The British are Coming!”**

Copyright 2008 Sun Microsystems, Inc. All Rights Reserved. Revision A

## What this lecture is about

### The Evolution of MUDs and MMOs

Copyright 2008 Sun Microsystems, Inc. All Rights Reserved. Revision A

## Lecture Overview, Day Two

- The evolution of the MMO
  - > From MUD to WOW in 30 minutes
- The Difficulties facing today's MMO developers
  - > The motivations for Project Darkstar

Copyright 2008 Sun Microsystems, Inc. All Rights Reserved. Revision A

## MUD's and MMOs

### Foreign DNA

Copyright 2008 Sun Microsystems, Inc. All Rights Reserved. Revision A

## Meanwhile, in merrie olde England

- The Birth of the MUD
  - > Multi-user text adventures
  - > Event driven servers
  - > Textual command based world simulation
    - > User submits text, eg “take sword”
    - > Server updates world state and sends textual reply
      - Others also see text for world state change

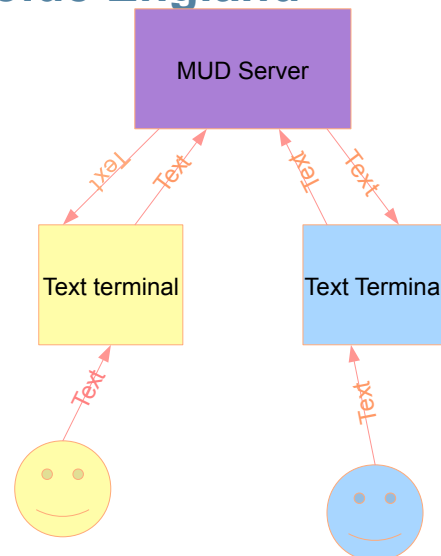

Copyright 2008 Sun Microsystems, Inc. All Rights Reserved. Revision A

## Meanwhile, in merrie olde England

- Used concept of “room” to break down n-squared communication problem
  - > Only those in room ‘see’ changes to room state
  - > Only those in room can act on others in room
  - > What if you run out of rooms?
    - Virtual ‘instanced’ rooms

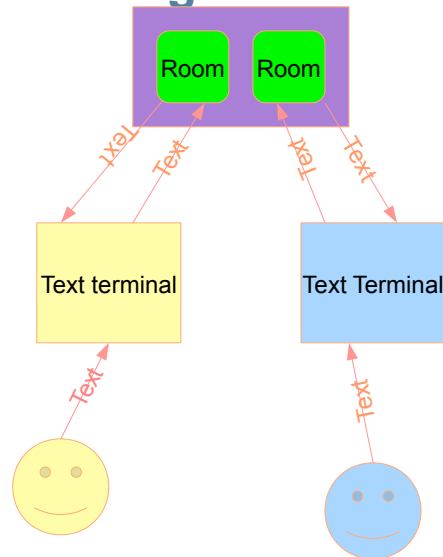

Copyright 2008 Sun Microsystems, Inc. All Rights Reserved. Revision A

## Ultima Online: The Visual MUD

- 2D game for client
  - > Levels or “maps” as in previous 2D games
  - > Each player on map has a position
- MUD for server
  - > Map becomes feature of room (Zone is born)
  - > Position on map becomes feature of player object

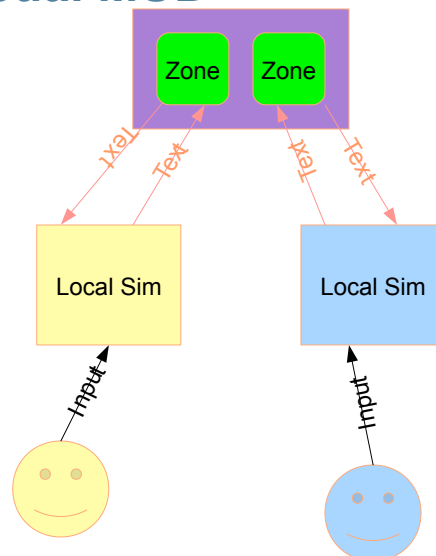

Copyright 2008 Sun Microsystems, Inc. All Rights Reserved. Revision A

## Ultima Online: The Visual MUD

- Issues?

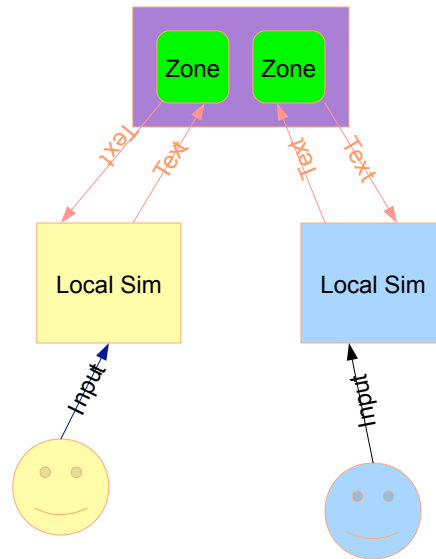

Copyright 2008 Sun Microsystems, Inc. All Rights Reserved. Revision A

## Ultima Online: The Visual MUD

- Issues?
  - > Over-crowding of “popular rooms”
    - > “fire marshal limit”
  - > Scalability limited by power of server
    - > Replicate server
  - > Server crash loses state of whole world
    - > Static worlds
    - > Persistence of users
      - Inventory
      - Experience
      - Quest flags

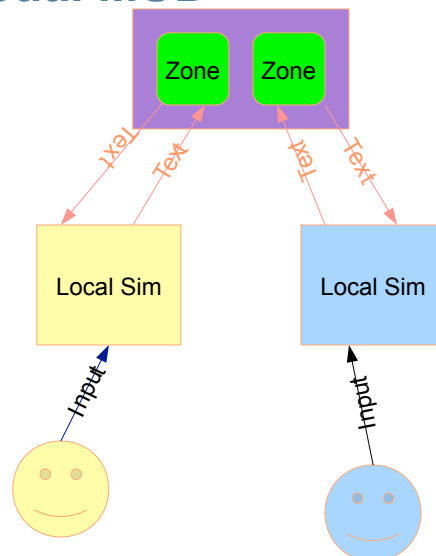

Copyright 2008 Sun Microsystems, Inc. All Rights Reserved. Revision A

## Everquest (EQ): The birth of the Shard

- EQ needed more power
  - > More users
  - > More work per user (3D world)
- Solved by clustering
  - > Server per Zone
  - > One cluster is called a 'shard'
    - > Shard is represented to user as one 'server'
    - > Terminology left over from UOL

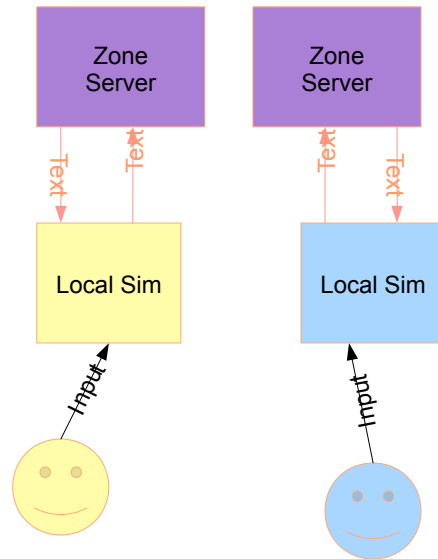

Copyright 2008 Sun Microsystems, Inc. All Rights Reserved. Revision A

## Everquest (EQ): Further load reduction

- EQ needed more power
  - > More users
  - > More work per user (3D world)
- Solved by clustering
  - > Moved MOB AI to separate server
    - > A system "player"
  - > Other special servers
    - > Commerce
    - > Chat
    - > Physics (CoX)

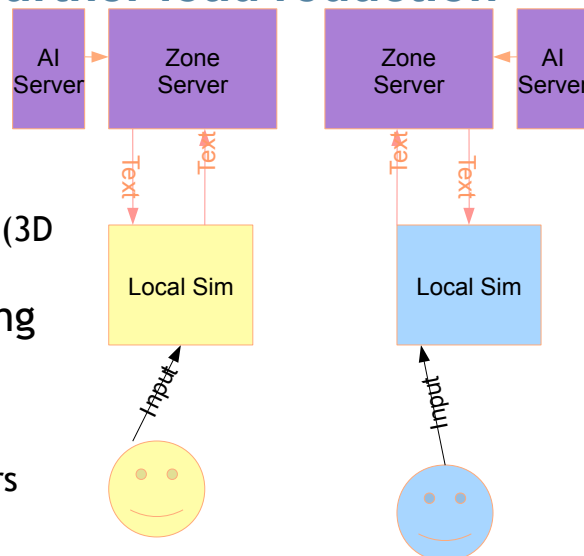

Copyright 2008 Sun Microsystems, Inc. All Rights Reserved. Revision A

## Everquest (EQ): Further load reduction

- Issues?
  - > Many single points of partial failure
  - > Zone server failure means loss of zone state
    - > Like UO but only partial loss of world
  - > Over crowded zones
    - > Return of the fire marshall
  - > Under utilized zones
    - > Wasted CPU resources

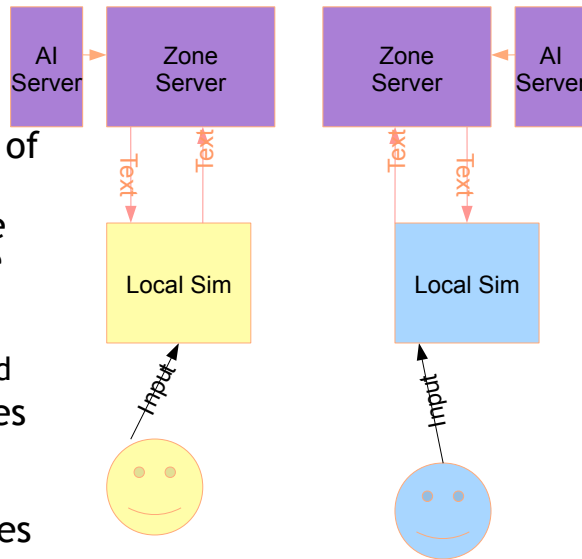

Copyright 2008 Sun Microsystems, Inc. All Rights Reserved. Revision A

## Phantasy Star Online: The rebirth of the Virtual Room

- Question: Can we do better scaling than shards?
- PSO Answer: Mission Instancing
  - > One standard zone as a “hub”
    - > Chat
    - > Create parties
    - > Get a 'mission'
  - > Mission is a virtual zone
    - > Created when party enters
    - > Destroyed when party leaves
    - > Limits n-squared to max party size
    - > Only has state while occupied
      - Can be run on a random machine from a pool

Copyright 2008 Sun Microsystems, Inc. All Rights Reserved. Revision A

## That's the state of the art today

- Various minor tweaks
  - > Incremental improvements
  - > Different mixes of techniques
- Things to remember
  - > Game development is a me-too business
    - > Technical evolution happens slowly due to risk
    - > Mostly focused on client experience
  - > Architectural innovation happens elsewhere
    - > Biggest leaps are usually the adoption of techniques already proven elsewhere

Copyright 2008 Sun Microsystems, Inc. All Rights Reserved. Revision A

## Issues Facing Today's Game Developer

- Single player games expanding user expectations
  - > Physics
  - > Advanced AI
  - > Interactive Environments
- Online user base growing non-linearly
  - > Great for business, bad for engineering
- All this == greater hunger for CPU and communication bandwidth

Copyright 2008 Sun Microsystems, Inc. All Rights Reserved. Revision A

# The Fundamental Technologies of the Internet

## A Packet

### •Fundamental IO Unit

#### –Header

- Generally an op-code
- Might have other info
  - Sender
  - Packet size
  - etc

#### –Payload

- The data being sent
- 0 or more fields
  - 0 if no data needed

```
Opcode=<PrivateMessage>  
From="Cyberqat"
```

```
Message="Mares eat oates,  
and does eat oats, and little  
lambs eat ivy.""
```

## Nesting Packets

- Entire packet can be the “payload” of a bigger packet

- Outer packet header prepended to inner packet

- Protocols “stack’ in this manner

- Can be many layers deep

Opcode=<InstantMessenger>

Opcode=<PrivateMessage>  
From=“Cyberqat”

Message=“Mares eat oates,  
and does eat oats, and little  
lams eat ivy.”“

## The TCP/IP Stack

From Computer Desktop Encyclopedia  
©2002 The Computer Language Co., Inc.

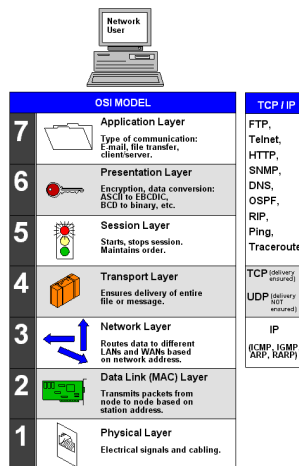

## Simplified Image of the Internet

- Internet is fundamentally made of two things

- Client computers

- Routers

- Data “hops” from one router to the next until it reaches its destination

- Multiple potential routes

- Routed by IP address

- Can watch

- Traceroute in Unix

- Tracert in Windows

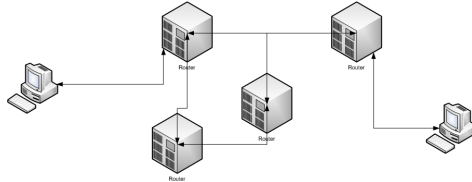

## Packet Loss

- Internet is inherently *unreliable*
  - Packets can be lost in transmission

**Why might a packet be lost?**

## Packet Loss

- Internet is inherently *unreliable*
  - Packets can be lost in transmission
    - Router failure
    - Line failure
    - Line partial failure (garbled data)
    - Router over-loaded (dropped from queue)

## Packet Order

- Internet is inherently *unordered*
  - Packets can arrive at destination in a different order than they were sent

**Why might they arrive out of order?**

## Packet Order

- Recall Internet has redundant paths
  - Each packet traces its own path
    - Each router makes a packet by packet selection of where to forward to based on current congestion
    - Decision is based on local knowledge only
    - Older packet might get “stuck” on a router queue

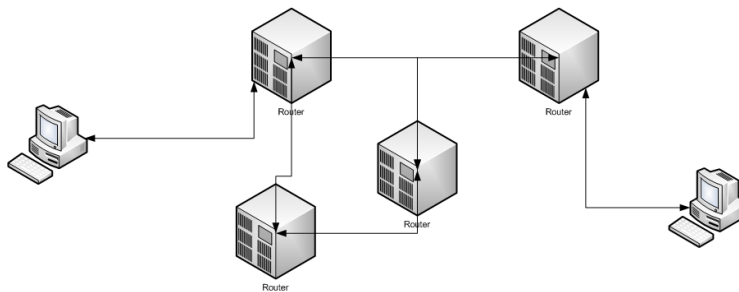

## TCP and UDP

- TCP and UDP are the fundamental data “carriers” for applications on the Internet
- UDP is
  - A datagram protocol
    - Connectionless, Packet Oriented
  - Unordered and Unreliable
    - Built more or less right on top of IP
- TCP
  - A stream protocol
    - Connections, stream oriented
  - Ordered and Reliable
    - Complex additional protocol layer

## TCP Reliability

- Internet is inherently *unreliable*
  - Routers drop packets when garbled or overloaded
  - Packets can arrive in any order
- Where does TCP get its guarantees?
  - Packets are sequence ordered on send.
  - If a later packet arrives before an earlier one, a resend is requested
  - Delivery of later packets held until earlier packets arrive
  - **This is an over-simplification**
    - 30 yrs worth of tuning and refining behind TCP

## Disadvantages of TCP

- TCP is easy to use
  - Reliable and ordered
  - Easier to secure

**What might be some disadvantages of TCP?**

## Disadvantages of TCP

- Can “stall”
  - Must wait for lost packet to continue
  - Creates latency spike
- Small additional overhead per packet
  - About 28 bytes
- For applications that are more sensitive to latency than loss, UDP can be a better choice.

## Application Level Protocols

- All built on top of TCP or UDP
  - HTTP (the web)
    - Built on top of..... ?
  - RTP (streaming audio and video)
    - Built on top of... ?
  - SSH
    - Built on top of... ?
  - Guild Wars
    - Built on top of... ?
  - Unreal Networking
    - Built on top of... ?

## Application Level Protocols

- All built on top of TCP or UDP
  - HTTP (the web)
    - Built on top of **TCP**
  - RTP (streaming audio and video)
    - Built on top of **UDP**
  - SSH
    - Built on top of **TCP**
  - Guild Wars
    - Built on top of **TCP**
  - Unreal Networking
    - Built on top of **UDP**

## Hybrids rare but possible

- TEN's BULLET Protocol
  - TEN was fundamentally a TCP/IP service
  - BULLET traded bandwidth for latency spike reduction
    - Main stream of game traffic TCP/IP
    - Sliding window of packets duplicated in UDP side-channel
    - UDP packets used to "fill in" during TCP stalls if available

# HTTP

- Built on top of TCP/IP
  - Every Put/Get involves...
    - Make TCP/IP connection
    - Send request (character coded)
    - Get response (character coded)
    - Close connection
  - Very Inefficient
    - Connection establishment expensive
    - Textual translation costs
  - Asynchronous by nature

## HTTP Synchronous Sessions

- Comet
  - AJAX technique to fake session
  - Polling based
    - “Long poll” to reduce costs
  - Really quite absurd
    - Even more inefficient than HTML
    - Lots of problems
      - Faking connectivity that HTML threw away

## HTTP Synchronous Sessions

- HTML 5 Web Sockets
  - Real session
    - Multiple interactions on a single connection
  - Still Textual

## Network Names

- IP uses numerical addresses
  - IP4
    - 4 bytes per address
    - 128.132.45.1
  - IP6
    - 8 octets per address
    - 2001:0db8:85a3:08d3:1319:8a2e:0370:7334

**How does [www.google.com](http://www.google.com) become 66.249.91.104?**

## Domain Name System (DNS)

- Every destination on the internet is served by a DNS registration server
  - Keeps a map of names to IP addresses
- DNS servers tell other DNS servers about the names registered with them
  - Loose, redundant network
    - Every DNS server has at least two other servers that it trades information with
    - Very reliable
    - Takes time to propagate

## Recall: Every computer has an IP Address

- IP address is like a street address
  - Routes packet through the internet
  - Packet eventually reaches router to which computer is connected
  - Ip address is bound to that router, like your street name is bound to your street

**How does mobile internet work?**

## Dynamic Host Configuration Protocol

- DHCP is a “conversation” between router and computer when computer first connects
- IP from a free pool is assigned to computer
- Computer generally keeps that Ip until disconnected
  - Might keep it longer on a “lease” arrangement
- Not just mobile computers
  - Often used by ISPs to remotely configure IP of clients

## DHCP and Security

**Why might DHCP make game security harder?**

## DHCP and Security

- IP is your “return address”
  - Every packet from you contains your IP so the other computer (“host”) can return information to you
- When net was new and hardwired, IP blocking was a common solution to bad behavior
- DHCP makes it very easy to “move” and thus avoid recognition
  - Makes “IP Blocking” very difficult on modern net
    - Have to block entire sections of an ISPs address space
    - Lots of innocents are caught in such a block

## Questions?

Tomorrow.... Tools and Facebook

## Part III: Tools and Facebook

### Categories of Tools

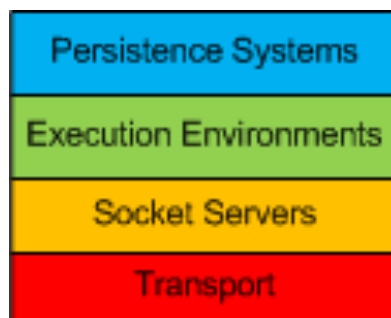

# Transports

## •Socket Libraries

- Symmetrical
  - Peer to Peer
  - 'Peer' could be a custom server
- "Tame" TCP/UDP
  - May or may not scale
- Could be custom protocol
  - Eg. Sliding window UDP
- Could provide discovery

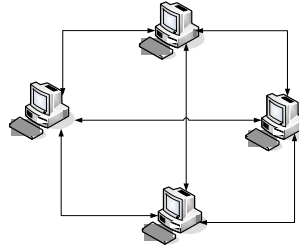

## •Providers

- Gamespy
- Various Open Source
  - Sun Grizzly Library
  - JGN
  - others

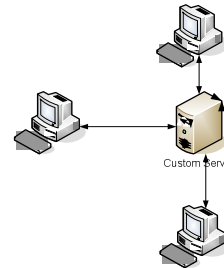

# Socket Servers

## •Star-network hub

- Built on top transport library
- Highly scalable
  - Thousands of connections
- Higher level net concepts
  - "Rooms" or "Channels"
- Generally provides discovery
- Could provide limited persistence
- Limited to no execution support

## •Providers

- Electro-Tank
- Smart Fox
- Red Dwarf
  - Subset of Red Dwarf functionality
- Others

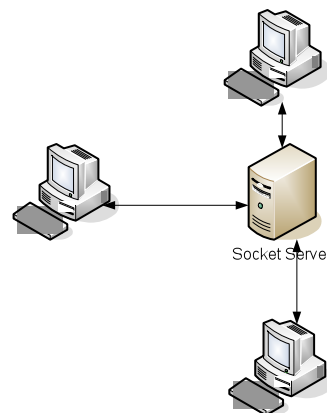

## Standard Java Persistence Models

- JDBC
  - SQL interface,
  - Supported by most RDBMs
    - ODBC bridge available
- JDO
  - Object database interface
  - Supported by many databases
- Custom ORMs
  - Hibernate
    - Supports many popular RDBMs
  - Per Database vendor

## Execution Environments

- Container Systems
  - Built on top socket servers
  - Highly scalable execution
  - Provide an application model
    - Servlets
    - Portlets
    - Darkstar Applications

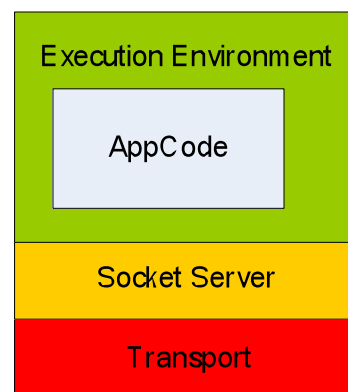

# Java Servlets

- Code that responds to HTTP requests
- Glassfish 3
  - Also does EJBs
  - Built ontop of Sun Grizzly TCP/IP library
  - Supports Standard Java persistence models
    - JDBC, JDO, Hibernate, etc

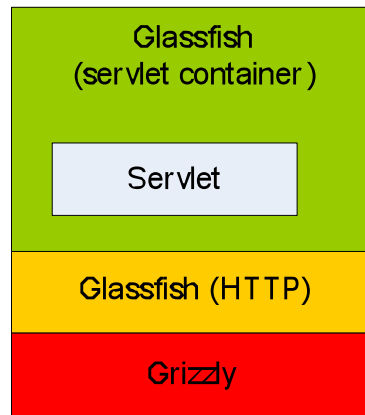

# Portlets

- Visual widget, part of a portal
  - Column oriented
  - Database backed
  - Has portal DB backing it
- Liferay
  - Is actually a servlet
  - Supports Standard Java persistence models
  - JDBC, JDO, Hibernate, etc
- Others
  - PHP, etc

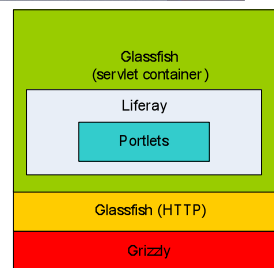
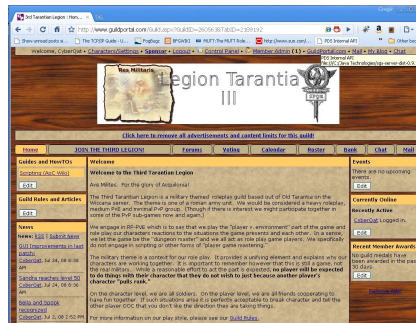

## Darkstar/RedDwarf

- Open source game server
  - Designed for low-latency response
- Runs “ManagedObjects”
  - Ala Project Darkstar
  - Almost POJO
  - Event driven
- Supports connected sessions
- Transparent Persistence
  - Non-relational
- Transparent Multi-tasking

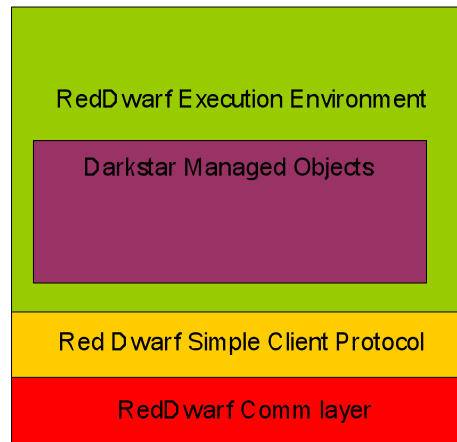

## Facebook

Or 50 Ways to Screw Your App

## Why Care about Facebook

- It's a market
  - 400 million current active users
- There's a lot of attention on it
  - VC money
  - Zynga looks attractive
    - Valued at 3 Billion dollars
    - \$250m gross in 2009
      - Net unknown
- A lot of jobs right now
  - Voracious for content
  - Developers relatively scarce

## Facebook Economics

- Or the dark side of social gaming
  - Millions of users, but only 3% spend any money
  - Very low avg per user return
    - Well under \$1/mo for most games
  - Each user has to use \*minimal\* resources
- Very intense schedules
  - Weekly feature releases (or more)
  - Constant player monitoring and game tweaking

## The Facebook Model

- Like the Web... only much worse
- Two Ways to be hosted on Facebook
  - The Old Way
    - FBML
  - The New Way
    - IFrame

## FBML

- Proprietary dialect/subset of HTML
  - Limits what you can do in HTML
  - Limits what you can do in Javascript
  - Limits what you can do in Flash
  - Slows ALL of it down

## How FBML works

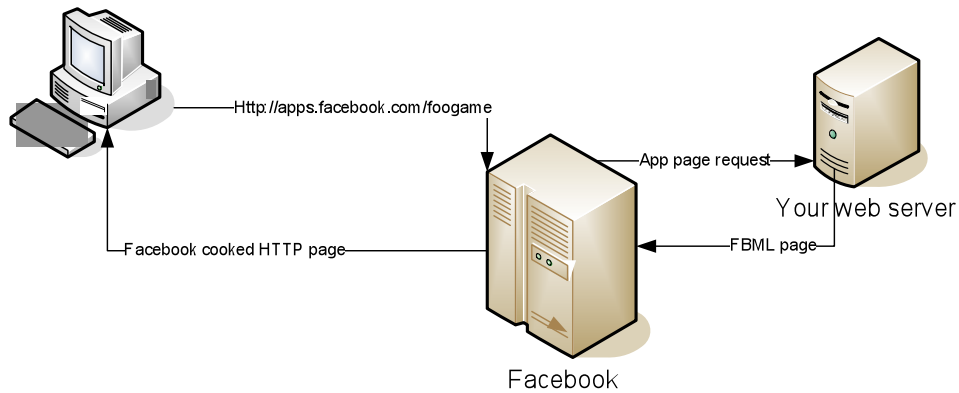

## FBML Issues

- Requires cooking through facebook
  - Slow
  - Can fail
- High security walls
  - Wrapper around Flash
    - Slow
    - Can fail
      - FBJS bridge a particular nightmare
  - Javascript limits
    - Name mangling a black art
    - Every Ajax request has to go back through Facebook

## How IFrame Works

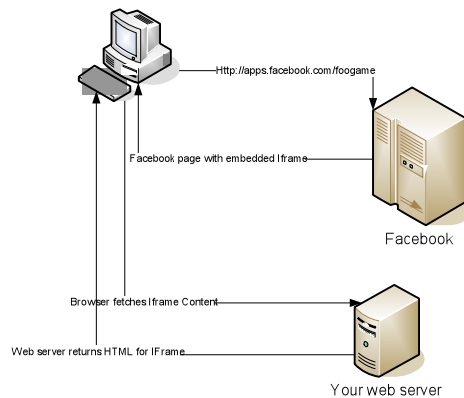

## IFrame Advantages and Issues

- Pro: Faster and more reliable at fetching content
  - Doesn't involve Facebook in every fetch
- Pro: Can mostly use straight HTML
- Con: More work to authenticate to Facebook
  - Need to authenticate to call facebook functions
  - API is not as complete
  - Requires using FB as a Web Service
    - Very Unreliable

## Moral of the Story

- **Facebook is HIGHLY unreliable at doing anything but serving its own pages**
  - Its overloaded
  - They break the API weekly in new ways
- Plan your game to rely on as little facebook functionality as you can get away with
  - IFrame
  - Avoid using their UI calls
- Plan for facebook to fail
  - Have good fallbacks for any place you call them

Questions?